



SG1400C4FP

Studio Generator

Amperage — 1400 @120/208V

3-Phase, 60 Hz, EPA Certified, Tier 4 Final

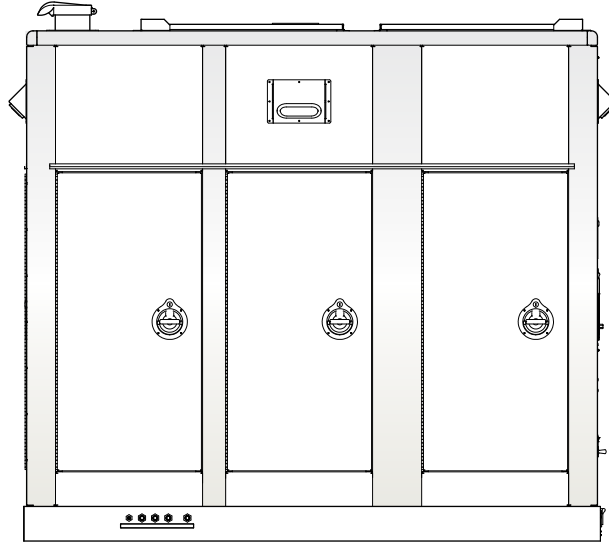

STANDARD FEATURES

- Heavy duty, 4-cycle, electronic direct injection, turbocharged, charged air cooler, variable speed fan, diesel engine provides maximum reliability.
- EPA emissions certified — Tier 4 Final emissions compliant.
- Crystal Sync internal engine control system maintains frequency to $\pm 0.25\%$.
- Full load acceptance of standby nameplate rating in a single step.
- Fuel/water separator removes condensation from fuel for extended engine life.
- Sound attenuated, weather resistant, aluminum housing. Fully lockable enclosure allows safe unattended operation.
- Automatic overhead doors equipped with inlet rain door and built in automatic intake door closure.
- Internal work lights within enclosure. Momentary toggle switch and 30-minute timer included.
- Standard product includes White paint that provides durability and weather protection.
- UN31A internal fuel tank with direct reading fuel gauges are standard.
- Brushless alternator reduces service and maintenance requirements and meets temperature rise standards for Class H insulation systems.
 - Automatic voltage regulator (AVR) provides precise regulation.
- 3-Position rotary voltage selector switch.
- Fully covered power panel. Three-phase terminals and single phase receptacles allow fast and convenient hookup for most applications including temporary power boxes, tools and lighting equipment. All are NEMA standard.
- ComAp IntelliGen 500 G2 Digital Controller with Colored Display.
 - Single or multiple gen-sets in parallel to mains operation with automatic back up function, multiple island operation.
 - Load sharing and VAr sharing via CAN.
 - High visibility heated LCD display.
 - Operational temperature range of -20° to 70° C (-4° to 158° F).
 - Remote 2-wire start/stop control.
 - Metered power output parameters include:
 - Voltage Amperage Kilowatts
 - True RMS (TRMS) is used with Voltage, Current and Power measurement.
 - Kilovolt amps Power Factor Hertz
 - Engine monitoring data over J1939.
- Cooling System rated to 104° F (40° C).
- AC monitoring along with fuel and DEF level indicators.
- Analog generator instrumentation including AC ammeter, AC voltmeter, frequency meter, ammeter phase selector switch, voltmeter phase selector switch, and voltage regulator adjustment potentiometer.
- Automatic safety shutdown system monitors the water temperature, engine oil pressure, low coolant, low DEF, overspeed, and overcrank. Warning lights indicate abnormal conditions.
- Emergency stop switch — When manually activated, shuts down generator in the event of an emergency.



SG1400C4FP

Studio Generator

SPECIFICATIONS

Generator Specifications	
Manufacturer/Model	Marathon Magnamax 431RSL4007
Type	4-Pole, Rotating Field
Exciter Type	Brushless, Voltage Regulated
Number of Leads	12 Lead
Insulation	NEMA MG1-1.66
Material	Class H
Amortisseur Windings	Full
Generator RPM	1800
Power Factor	0.8
Coupling	Single bearing, flexible
Cooling Air Volume	1200 CFM
Voltage Regulation (no load to full load)	±1%
Single Step Load Acceptance per NFPA 110	100% of Rating

Engine Specifications	
Manufacturer/Model	Cummins / QSB7-G9
Type	4-cycle, charged air cooled, turbocharged, EGR, DOC, SCR
Cylinder Arrangement	6 In-Line
Displacement	409 in ³ (6.7 liters)
Bore	4.21 in. (107 mm)
Stroke	4.88 in. (124 mm)
Compression Ratio	17.3:1
Cylinder Block	Cast iron
Cylinder Head	Cast iron
Crankshaft	Nodular iron
Brake Mean Effective Pressure (BMEP)	304 psi (2096 kPa)
Rated RPM	1800 RPM
Prime Power at Rated RPM	282 hp (210 kWm)
Governor Type	Crystal Sync Electronic
Frequency Regulation: no load to full load	Isochronous under varying loads from no load to 100% rated load
Frequency Regulation: Steady State	±0.25% of mean value for constant loads from no load to full load.
Air Cleaner Type	Replaceable, Paper insert

Fuel System		
Fuel Injection Pump Make	Bosch HPCR	
Recommended Fuel	ASTM-D975 / No.2-D Ultra Low Sulphur	
Fuel Filter	Spin-on type	
Max. Fuel Flow	50 gal/hr (189 L/h)	
Trailer Fuel Tank Capacity	145 gal (548 l)	
Fuel Consumption:	gph	lph
At full load	13.5	51.1
At 3/4 load	10.3	38.9
At 1/2 load	7.2	27.3
At 1/4 load	4.1	15.5
DEF Tank Capacity	10 gal (37.8 l)	

Cooling System	
Radiator Design	Horizontal Discharge
Ambient Temperature Rating	104°F (40°C)
Coolant Capacity (with radiator)	12 gallons (45 liters)
Coolant Flow	38 gal/min (144 l/min)
Heat Rejection to Charge Air Cooler	2213 Btu/min (39 kW)

Exhaust System	
Exhaust Flow at Rated kW	1038 cfm
Exhaust Temperature at Rated kW	795 °F (424 °C)
Maximum Allowable Back Pressure Before DOC	108.7 in/wc (27 kPa)
Heat Rejection to Exhaust	7178 Btu/min (126 kW)

Engine Electrical System	
Battery Charging Alternator - Make	Cummins
Ground Type	Negative
Volts (DC)	24 V
Ampere Rating	70 A
Starter Motor Make/Model	Cummins
Starter Motor Rated Voltage	24 VDC
Starter Motor Battery Capacity	2 x 750 cca

Amperage	
Rated Voltage	Maximum Amps
1Ø 120 Volt	486.1
1Ø 240 Volt	243.1
3Ø 120 Volt	350.8 x 3
3Ø 208 Volt	607.2
3Ø 480 Volt	263.1
Main Line Circuit Breaker Rating	600

Lubrication System	
Type	Full pressure system
System Capacity - With Filter	5 gallons (18.9 liters)
Oil Filter	Full flow, spin-on
Oil Pressure At Rated Speed	25-60 psi (172-414 kPa)

WARRANTY*

Cummins Engine

12 months from date of purchase with unlimited hours.

Generator

24 months from date of purchase or 2000 hours (whichever occurs first).

Trailer

12 months excluding normal wear items.

*Refer to the express written, one-year limited warranty sheet for additional information.

NOTICE

Specifications sheet is subject to change and is not intended for use in installation design.



SG1400C4FP

Studio Generator

GENERATOR CONTROLLER

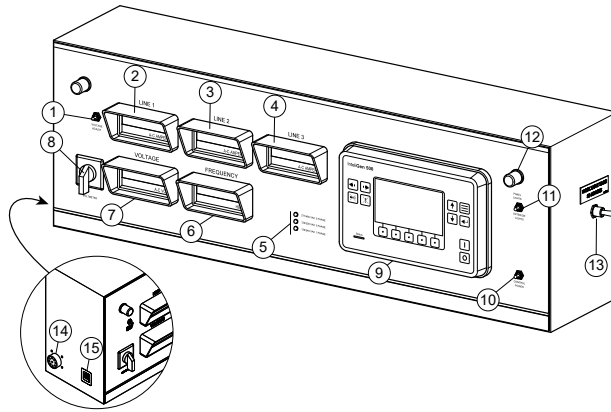

CONTROL PANEL FEATURES

1. Voltage Adjust Switch
2. Line 1 AC Amps Display
3. Line 2 AC Amps Display
4. Line 3 AC Amps Display
5. Voltage Status LEDs
6. Frequency Display
7. AC Voltmeter Display
8. Voltmeter Selector Switch
9. Digital Controller
10. Controller Power Switch
11. Light Switch
12. Panel Lights
13. Light Timer Control
14. Engine Com Connector
15. Ethernet CAT5E Connector

OPTIONAL GENERATOR FEATURES

- **Battery Charger** — provides fully automatic and self-adjusting charging to the generator's battery system.
- **External Lighting** — quantity 4 LED lamps, with countdown timer switch to illuminate surrounding area.
- **Fire Extinguishers** — 5-lbs bottle with a box.
- **Jacket Water Heater** — for easy starting in cold weather climates.
- **Customized Paint Option** — customer RAL (Paint Code) required at time of order.
- 6 x Sets — Camlok receptacles
- 6 x Sets — Camlok receptacles, 2 x ea, 50A twistlock outlet receptacles
- 6 x Sets — Camlok receptacles, 2 x ea, 50A twistlock outlet receptacles, 2 x ea, 100A Bates receptacles
- 6 x Sets — Camlok receptacles, 2 x ea, 100A Bates receptacles

OPTIONAL TRAILER PACKAGES

- **Trailer Mounted Package** — meets National Highway Traffic Safety Administration (NHTSA) regulations. Trailer is equipped with electronic or surge brakes on all axles.

OPTIONAL MOUNTING PACKAGES

- **Customer Supplied Tractor or Trailer Mounting Kits**



SG1400C4FP

Studio Generator

SKID-MOUNT DIMENSIONS

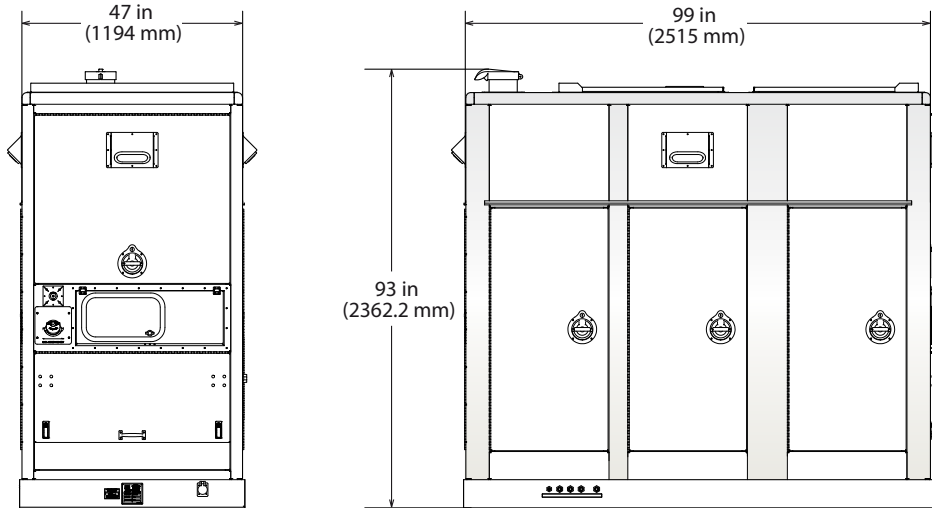

TRAILER-MOUNT DIMENSIONS

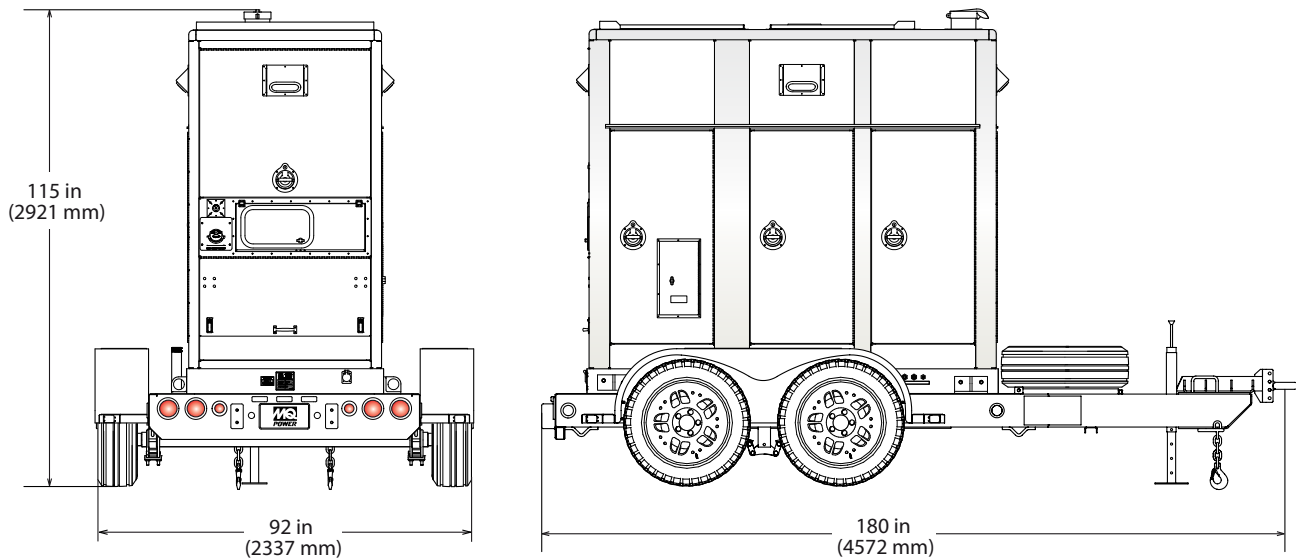

SG1400C4FP Weights*

Dry Weight	5,900lbs (2,676 kg)
Wet Weight	6,181 lbs (2,803 kg)

* Weights do not include options.

SG1400C4FP (with TRLRSG1600XFH) Weights*

Dry Weight (with TRLRSG1600XFH)	8,620 lbs. (3,909 kg)
Wet Weight (with TRLRSG1600XFH)	9,650 lbs. (4,376 kg)

Generator can be placed on MQ Trailer Model TRLRSG1600XFH (H/E).

NOTICE

Features and Specifications are subject to change without notice.

© COPYRIGHT 2025 MULTIQUIP INC.
SG1400C4FP Rev. # 2 (03/03/25)



MULTIQUIP
6141 Katella Avenue Suite 200
Cypress, CA 90630
310-537-3700
E-MAIL: mq@multiquip.com
WEBSITE: www.multiquip.com