



ST2047

MULTIQUIP® 2" Submersible Pump

GALLONS PER MINUTE

85 (322 L)

HEAD

46 ft (14 M)

POWER

115V, Single Phase, 60Hz

APPLICATIONS

CONSTRUCTION

Standing Water, Well Casings, Excavation, Site Drainage, and Manholes

INDUSTRIAL

Water Supply from Lakes/Rivers, Wastewater, Quarries, Flooded Rooftops, and Irrigation

RESIDENTIAL

Flooded Basements, Swimming Pools, Decorative Waterfalls and Fountains

STANDARD FEATURES

- **Heavy-duty 1 HP motor** for maximum reliability.
- 2" (NPT) male discharge port.
- **Compact steel housing** and streamlined design allows pump to fit into 8" pipes.
- Pumps liquids up to 104° F.
- **49.2 ft molded power cord** with strain relief.
- **Aluminum motor casing** serves as heat conductor.
- **Internal thermal protection** prevents motor failure due to overloading and running pump dry.
- UL/CUL listed.

WARRANTY*

ST2047: 12 months from date of purchase.

Hoses: 3 months from date of purchase.

Float Switches: 3 months from date of purchase.

CB3: 3 months from date of purchase.

*Refer to the MULTIQUIP NEW PRODUCT LIMITED WARRANTY FOR FULL TERMS AND CONDITIONS.



FEATURES

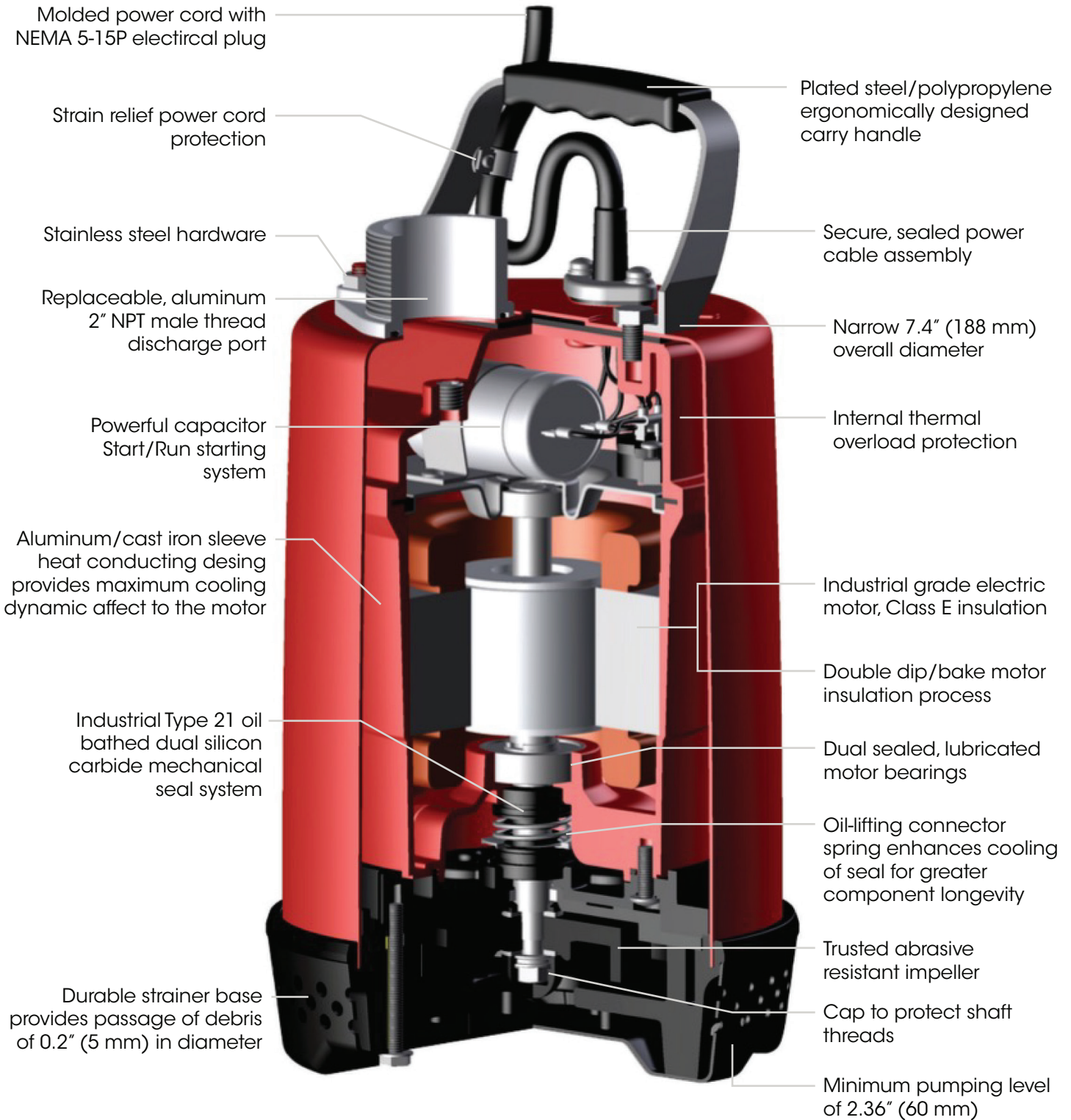

PUMP CURVE

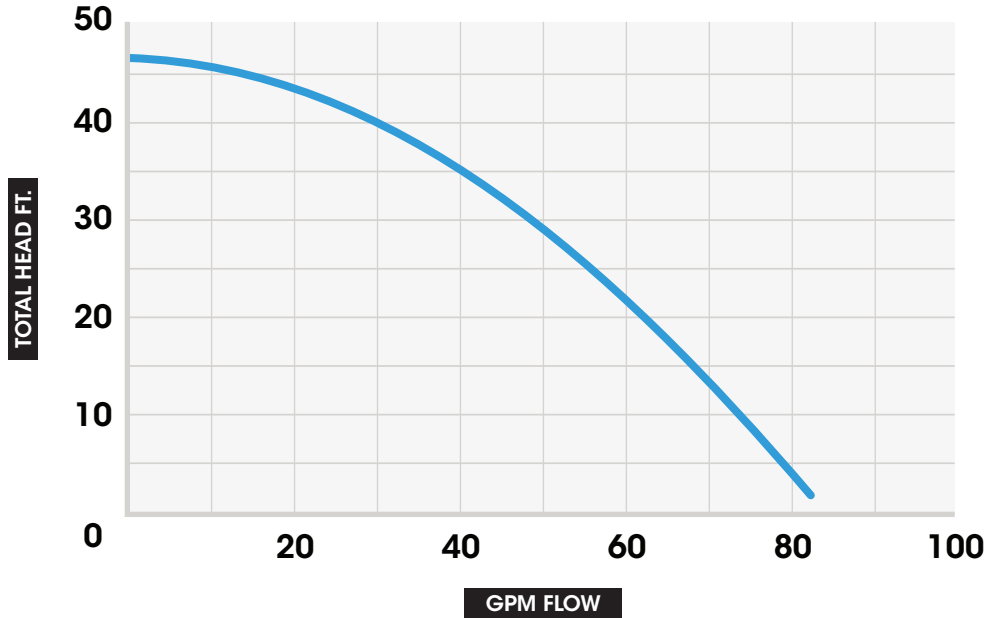

PUMP DIMENSIONS

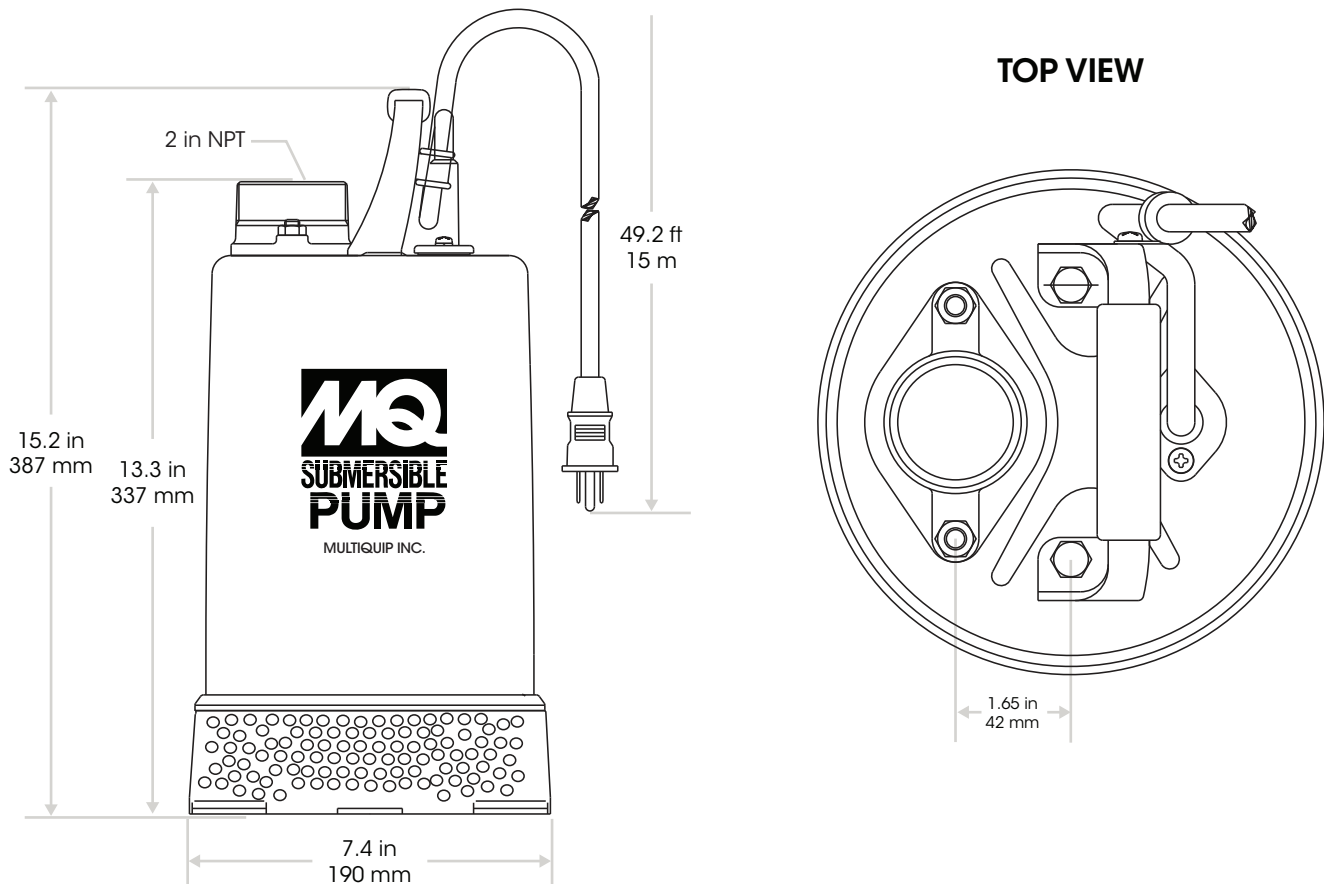

SPECIFICATIONS

PUMP SPECIFICATIONS	
MODEL	ST2047
TYPE	CENTRIFUGAL SUB PUMP
IMPELLER	NEOPRENE RUBBER OVER STEEL
SUCTION/DISCHARGE SIZE	2.00 in (50 mm)
MAX. PUMPING CAPACITY	85 GALLONS/MIN (322 L/MIN)
MAX. HEAD	46 ft (14 M)
PSI	20.3
MIN. PUMPING LEVEL	2.36 in (60 mm)
MIN. SUBMERGENCE	19.2 in (487.7 mm)
MAX. SOLID HANDLING	0.2 in (5 mm)
HORSEPOWER	1 (0.746 kW)
VOLTAGE	115V
PHASE	1Ø
FREQUENCY	60 Hz
STARTING AMPS	25
RUNNING AMPS	9.8
MIN. GENERATOR KW TO START/RUN	2.9 kW/1.13 kW
INSULATION	CLASS E
MAX. FLUID TEMPERATURE	104°F (40°C)
THERMAL OVERLOAD PROTECTION	STANDARD
ROTATION	COUNTERCLOCKWISE
RPM	3,250 (±30)
MECHANICAL SEAL SYSTEM	OIL BATHED, DUAL SILICON CARBIDE, CORROSION RESISTANT
MECHANICAL SEAL OIL CAPACITY	4.0 oz (120 cc)
MECHANICAL SEAL OIL TYPE	SHELL TETRA 10SP OR EQUIVALENT
MECHANICAL SHAFT	STAINLESS STEEL
O-RINGS	NITRILE RUBBER
HARDWARE	STAINLESS STEEL
SALT OR CHEMICALS	NO
POWER CABLE PLUG	NEMA 5-15P
POWER CABLE PROTECTION	STRAIN RELIEF
POWER CABLE LENGTH	49.2 ft (15 M)
DRY WEIGHT	33.1 lb (15.0 kg)

FLOAT SWITCH FEATURES	SW1A	SW1WOPA	SW2A
SINGLE MECHANICAL FLOAT	X	X	—
DOUBLE MECHANICAL FLOAT	—	—	X
120VAC	X	X	X
PIGGY-BACK PLUG (NEMA 5-15)	X	—	X
OPEN WIRE END, FOR CONTROL BOX APPLICATIONS ONLY	—	X	—
CORROSION RESISTANT PVC HOUSING	X	X	—
CORROSION RESISTANT HIGH-IMPACT HOUSING	—	—	X
HEAVY-DUTY CONTACTS	X	X	X
OPERATES IN WATER UP TO 104°F (40°C)	X	X	X
ADJUSTABLE RANGE 7" TO 36" (18 - 91 CM)	X	X	—
ADJUSTABLE RANGE 3" TO 48" (7.6 - 122 CM)	—	—	X
16 GAUGE CORD FLOAT SWITCH CORD 20' (6.1 METERS)	X	X	—
14 GAUGE CORD FLOAT SWITCH CORD 20' (6.1 METERS)	—	—	X
PRESSURE TESTED TO 60'	X	X	—
INCLUDES MOUNTING CLAMPS	X	X	X
UL LISTED	X	X	X
CSA CERTIFIED	X	X	X



OPTIONS

DISCHARGE HOSES

- **HD250C** - 2" x 50 ft., 75psi, NPS thread
- **HDQ250C** - 2" x 50 ft., 75psi NPT thread, includes one quick disconnect coupler
- **A200A** - 2" type A coupler, male quick disconnect x female NPT



HD250C



HDQ250C



A200A

CB3 CONTROL BOX

Offered for convenient MANUAL/AUTO and float switch operations. Water resistant fiberglass housing and cable connectors prevent moisture from entering into box. Features operation switch and running light. Includes two SW1WOPA float switches.

Voltage - 120V
Phase - 1Ø
Amps (FLA) - 40A

UL Listed



Note: The ST2047 is designed with internal thermal overload protection and does not require extra electrical protection.

NOTICE Features and Specifications are subject to change without notice.