

MQ ST41230

MULTIQUIP® 4" Submersible Pump

GALLONS PER MINUTE

423 (1600 L)

HEAD

138 ft (42 M)

POWER

230V, Three-Phase, 60Hz

APPLICATIONS

CONSTRUCTION

Standing Water, Well Casings, Excavation, Site Drainage, and Manholes

INDUSTRIAL

Water Supply from Lakes/Rivers, Wastewater, Quarries, and Irrigation

STANDARD FEATURES

- **Heavy-duty 10 HP motor** for maximum reliability.
- 4" (NPT) male discharge port.
- **Compact housing** and streamlined design allows pump to fit into 14" pipes.
- Dynamically balanced, high chrome impeller for abrasion resistance.
- Pumps liquids up to 104° F.
- Pass spherical solids up to 0.6" diameter.
- Dewater flat surfaces up to 5.5".
- **Industrial 230V, 60Hz three-phase oil-free motor** equipped with thermal overload, over-current protection.
- **Oil-filled, double mechanical pump seals** provide reliable protection in the most demanding conditions.
- Heat-treated output shaft, 420J2 stainless steel construction for corrosion resistance.
- Stainless steel outer casing and strainer.
- **49.2 ft molded power cord** with strain relief.

WARRANTY*

ST41230: 12 months from date of purchase.

Hoses: 3 months from date of purchase.

Float Switches: 3 months from date of purchase.

CB12A6974: 3 months from date of purchase.

*Refer to the MULTIQUIP NEW PRODUCT LIMITED WARRANTY FOR FULL TERMS AND CONDITIONS.



FEATURES

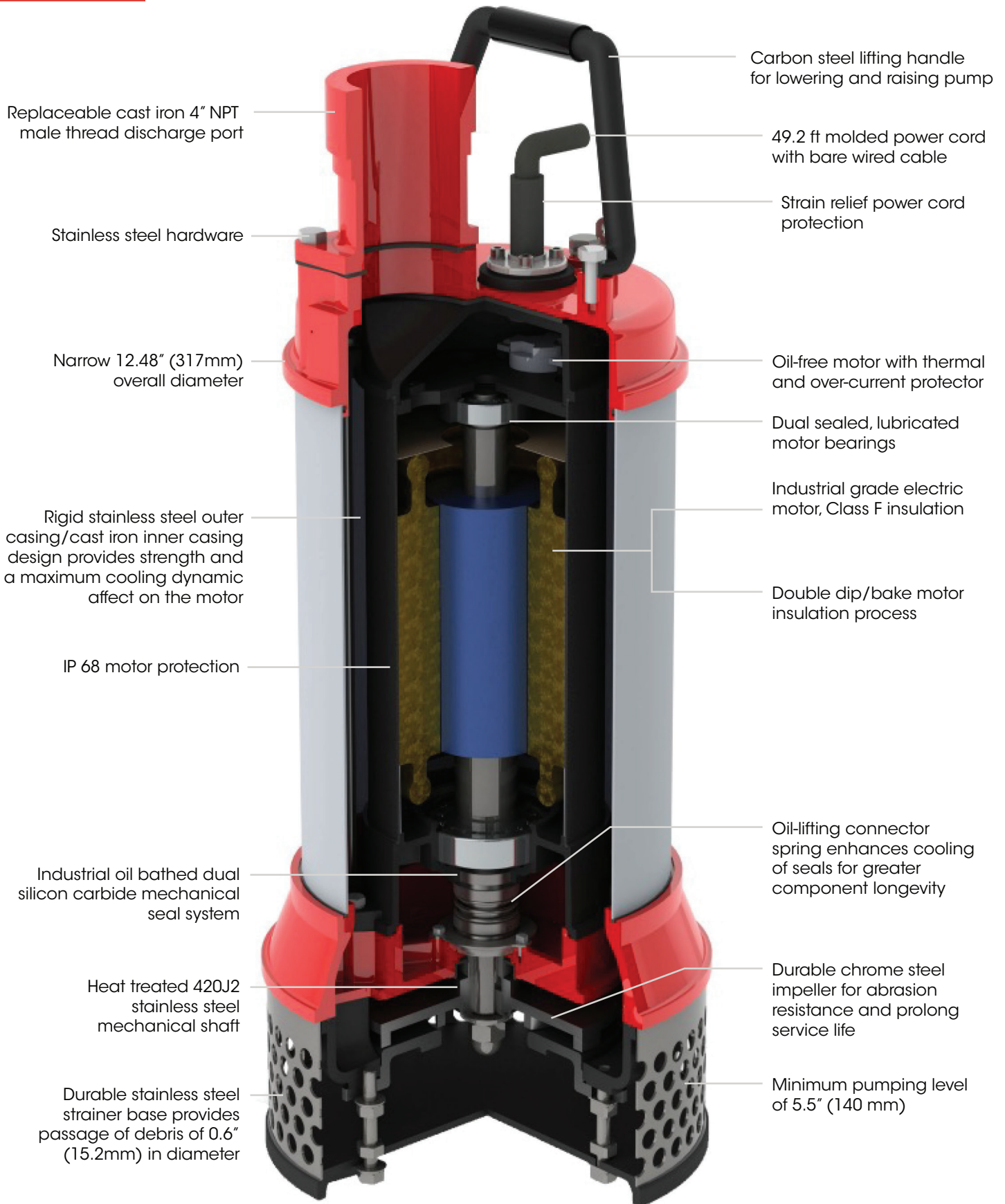

© COPYRIGHT 2026 MULTIQUIP INC. (REV 03172026)

PUMP CURVE

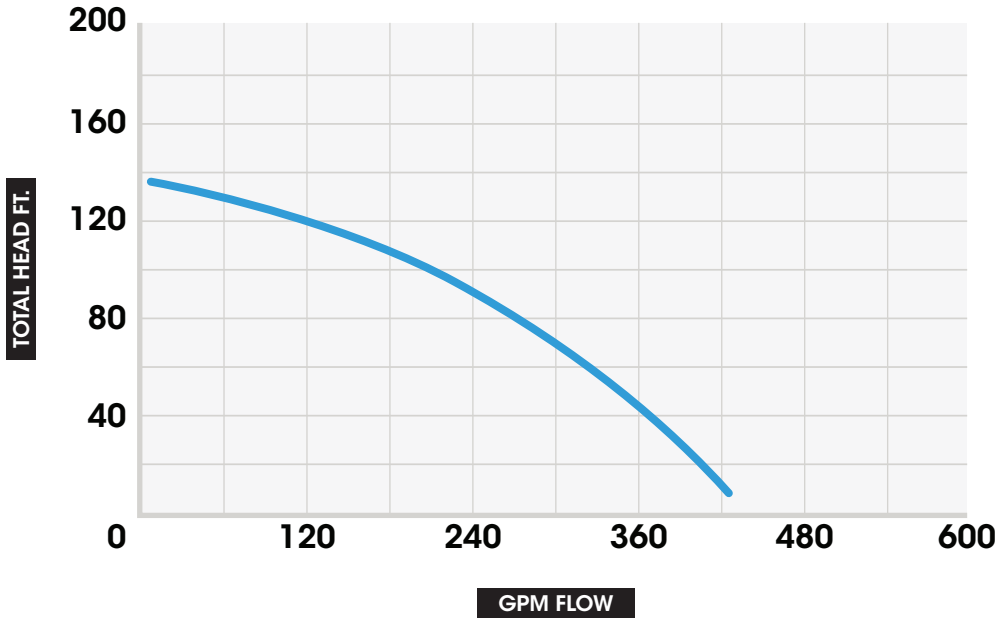

PUMP DIMENSIONS

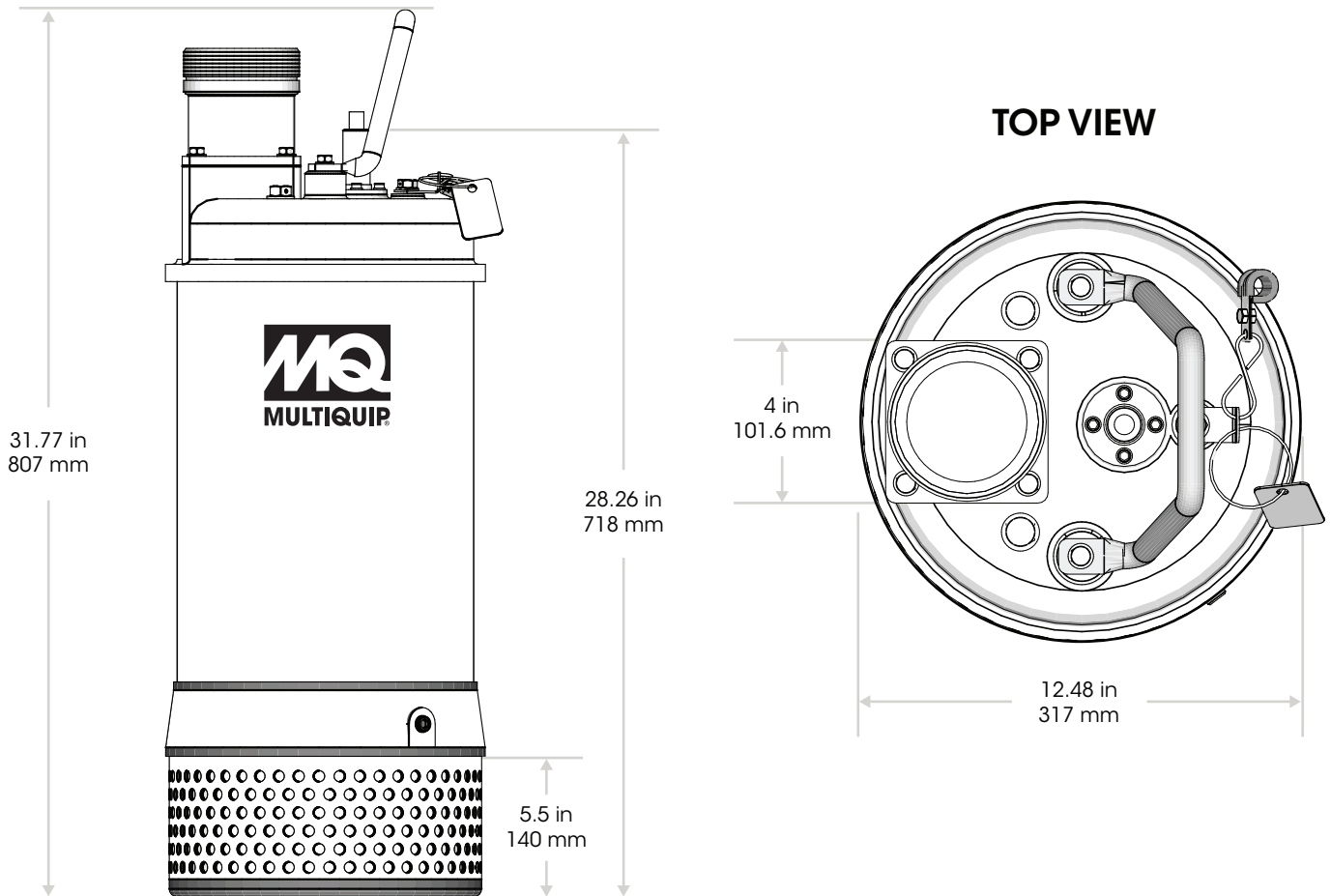

SPECIFICATIONS

PUMP SPECIFICATIONS	
MODEL	ST41230
TYPE	CENTRIFUGAL SUB PUMP
IMPELLER	CHROME STEEL
SUCTION/DISCHARGE SIZE	4.00 in. (101.6 mm)
MAX. PUMPING CAPACITY	423 GALLONS/MIN (1,600 L/MIN)
MAX. HEAD	138 ft. (42 M)
PSI	59.7
MIN. PUMPING LEVEL	5.5 in. (140 mm)
MIN. SUBMERGENCE	34.3 in. (871.2 mm)
MAX. SOLID HANDLING	0.6 in. (15.2 mm)
HORSEPOWER	10 (7.46 kW)
VOLTAGE	230V
PHASE	3Ø
FREQUENCY	60 Hz
STARTING AMPS	150.5
RUNNING AMPS	30.0
MIN. GENERATOR KW TO START/RUN	20 kW/9.7 kW
INSULATION	CLASS F
MAX. FLUID TEMPERATURE	104°F (40°C)
THERMAL OVERLOAD PROTECTION	STANDARD
ROTATION	CLOCKWISE
RPM	3,600 (±30)
MECHANICAL SEAL SYSTEM	DOUBLE MECHANICAL SEALS (LOWER SILICON CARBIDE V SILICON CARBIDE, UPPER CARBON/CERAMIC) IN OIL CHAMBER
MECHANICAL SEAL OIL CAPACITY	40.6 oz (1,200 cc)
MECHANICAL SEAL OIL TYPE	ISO VG32 OR EQUIVALENT
MECHANICAL SHAFT	STAINLESS STEEL
O-RINGS	NITRILE RUBBER
HARDWARE	STAINLESS STEEL
SALT OR CHEMICALS	NO
POWER CABLE PLUG	BARE WIRES
CABLE TYPE	PVC, 5.5mm ² X 4C, 60° C, 600V, 10AWG, CSA, AWM
POWER CABLE PROTECTION	STRAIN RELIEF
POWER CABLE LENGTH	49.2 ft. (15 M)
DRY WEIGHT	205 lb. (93 kg)

FLOAT SWITCH FEATURES	SW1WOPA
SINGLE MECHANICAL FLOAT	X
OPEN WIRE END, FOR CONTROL BOX APPLICATIONS ONLY	X
CORROSION RESISTANT PVC HOUSING	X
HEAVY-DUTY CONTACTS	X
OPERATES IN WATER UP TO 104°F (40°C)	X
ADJUSTABLE RANGE 7" TO 36" (18 TO 91 CM)	X
16 GAUGE CORD FLOAT SWITCH CORD 20' (6.1 M)	X
PRESSURE TESTED TO 60'	X
INCLUDES MOUNTING CLAMPS	X
UL RECOGNIZED	X
CSA CERTIFIED	X



CB12A6974



SW1WOPA

CB12A6974 CONTROL BOX

Offered for model ST41230 (230V 3Ø). Magnetic starter, electronic overload protection, power spike control, and short circuit protection. Watertight UL/CUL enclosure and cable glands that support float switches. ON/OFF switch with running lights. Three K69 heater elements included.

SW1WOPA float switch sold separately.

Voltage - 230V
Phase - 3Ø
Amps (FLA) - 28.6A

UL Listed

OPTIONS

DISCHARGE HOSES

- **HD450C** - 4" x 50 ft., 60psi, NPS thread
- **HDQ450C** - 4" x 50 ft., 60psi NPT thread, includes one quick disconnect coupler
- **A400A** - 4" type A coupler, male quick disconnect x female NPT



HD450C



HDQ450C



A400A

NOTICE Features and Specifications are subject to change without notice.