



# STX Ride-On Trowel (S/N BL2001337 and Below)

## MULTIQUIP Tapered Keyless Spider Installation Instructions (Eaton Motors Only)

The following instructions are intended to assist the user in the installation of a keyless spider. Please read all assembly instructions before installing the kit.

### REQUIRED TOOLS

- Torque Wrench
- Hammer
- Air Compressor
- Spider Removal Tool (P/N 23340E)
- Loctite™ 271
- Loctite™ 240
- Chemsearch™ (Rust Lubricant)
- Forklift/Hoist
- Heavy Duty Jack Stands

### PARTS

Verify that all parts are accounted for. See Table 1 below.

Table 1. Tapered Spider Kit Parts				
Item	Qty.	Part No.	Description	Remarks
1	1	22578	Spider STX Service Kit Eaton	INCLUDES ITEMS 2 THRU 12
2	6	11602	Screw, SHC 3/8-16 X 1/4	
3	1	1477	Loctite™ #242	Blue
4	1	19379-014	Loctite™ #271	Red
5	1	20121	Plug, Spider Snap In	
6	1	22465	Screw, HHC 3/4-16 X 2.5	
7	1	20179	Screw, HHC 3/4-16 X 2	
8	1	933247	Washer, Flat 3/4 GRD 9	
9	1	23380	Gage	
10	1	22576	Spider Plate, 6-Blade	Eaton Only
11	1	23340E	Puller, Tapered Spider	
12	2	22577	Spacer, Thrust Bearing	

### WORK SAFELY!

Only a **qualified service technician** with proper training should perform this installation. Follow all shop safety rules when performing this installation.

### SPIDER CONFIGURATIONS

**ALWAYS** ensure that both the left and right spiders assemblies are configured the same, meaning key versus keyless. A **keyless** tapered spider (new style) will be torqued to 350 ft-lb (475 N·m) and will be marked on the backside of the spider as "TQ350E" (See Figure 7). A **keyed** tapered spider (old style) will be torqued to 130 ft-lb (176 N·m).

The use of old style spiders with new style spiders is not recommended.

### NOTICE

**NEVER** operate a trowel with an old style and new style spider installed. This type of configuration can cause severe damage to the trowel.

### LIFTING THE TROWEL

1. Attach one end of a lifting strap or chain around the lift loops on each side of the trowel. Attach the other end of the lifting strap or chain to the lifting device (Figure 1).

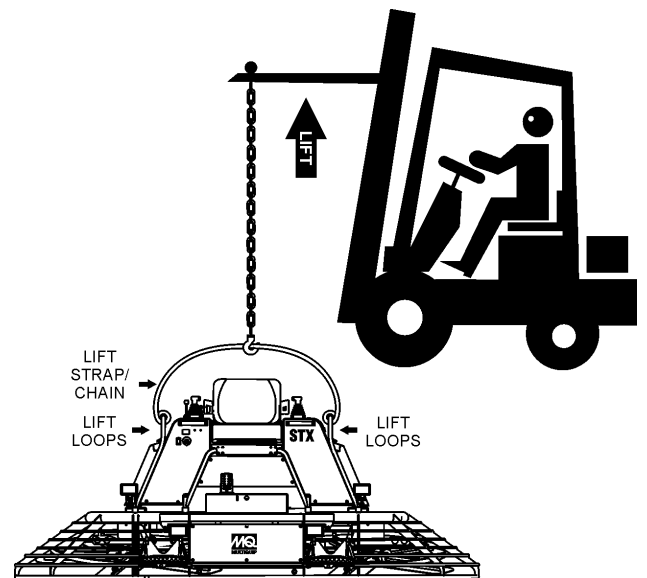
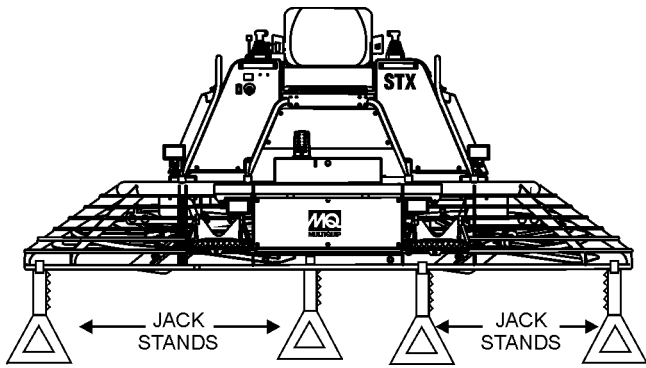

Figure 1. Lifting the Trowel

2. Next, place the trowel on heavy duty jack stands as shown in Figure 2.



**Figure 2. Jack Stand Support**

## SPIDER REMOVAL

### **CAUTION**

The spider removal process will result in the sudden separation of the spider assembly from the hydraulic motor shaft.

Position the catch chains so that they are equally spaced, with no more than 3 to 4 inches of slack. This will prevent the spider assembly from falling and striking personnel, causing bodily harm. The catch chains shown in Figure 3 are shorter than they appear. They are shown this way for clarity only.

1. Attach one end of three equally spaced straps or catch chains to the **stabilizer ring** (Figure 3). Attach the other end of these straps or chains to the **bottom guard ring** in a manner that would prevent the spider assembly from falling. **NEVER** use the **intermediate guard rings** to support the spider assembly.

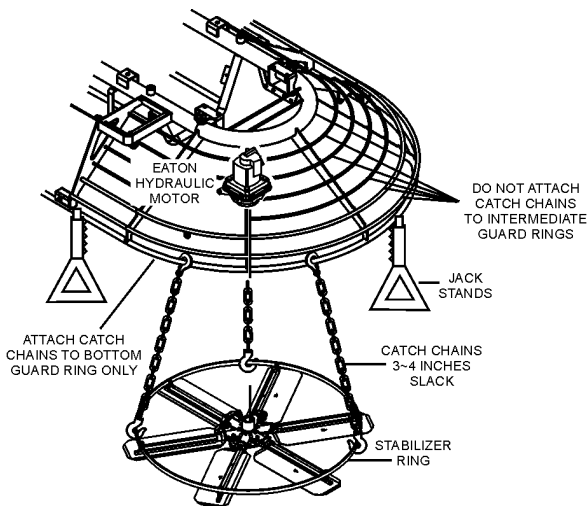

**Figure 3. Supporting Stabilizer Ring**

2. To assist with the removal of the spider assembly, threads for a removal tool have been machined into the bottom center of the spider.
3. Remove the snap-in spider dust cover plug from the bottom of the spider. This plug has been provided to protect the spider threads from contaminants.
4. Remove the existing spider retaining bolt and retaining washer. Discard both of these items.
5. Before proceeding, make sure the threads are clean and free of debris. If necessary, use compressed air or brake cleaner solvent to remove any debris that may have accumulated on the threads.
6. When separating the spider assembly from the hydraulic motor, apply a small amount of rust lubricant to the threads.
7. Insert spider removal tool (P/N 23340E) into machined threads on spider (Figure 4) and torque to 300 ft-lb (407 N·m).

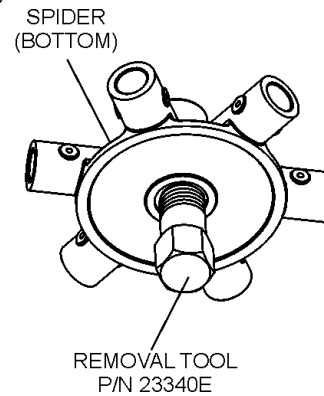

**Figure 4. Removal Tool**

8. If the spider assembly does not disengage, remove the torque wrench and strike the end of the spider removal tool with a hammer several times to dislodge the spider.
9. Repeat steps 7 and 8 until spider assembly disengages.
10. Once the spider assembly has been removed, place on a flat surface where it will not get damaged. Please note the orientation (left or right) of each spider. Orientation is defined from the operator's seat. Mark and tag each spider either left or right.

### **NOTICE**

**ALWAYS** mark and tag each spider assembly prior to removing it from the trowel. Left and right is defined from the operator's seat.

## SPIDER INSTALLATION

### NOTICE

**NEVER** use any type of anti-seize or lubricant when installing the tapered fit components of the spider onto the hydraulic drive motor shaft.

1. Before assembling, ensure that the tapered hole in the spider is clean. Spray with brake cleaner to remove any contaminants that may have accumulated on the tapered surface of the spider. Use compressed air to blow away any remaining residue.
2. Remove trowel arms and associated components (Figure 5) from old spider (removed) assembly and place onto **new tapered spider**. Tighten trowel arms and associated hardware securely. If required, reference parts manual as guide for reassembly.

### NOTICE

Apply Loctite™ 242 (BLUE) to the six HHC screws P/N 11602 as shown in Figure 5.

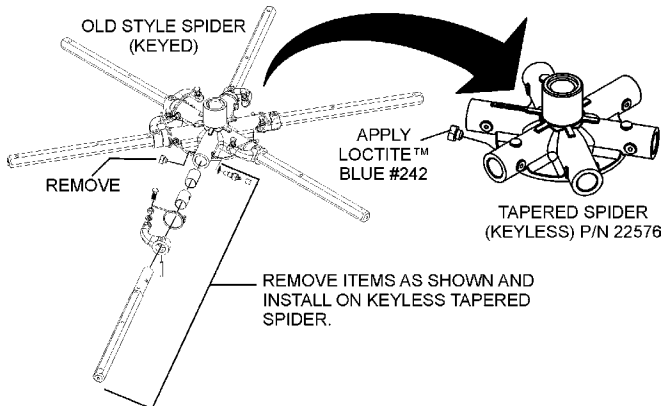

**Figure 5. Spider Components**

3. Make sure the threads inside the hydraulic drive motor shaft are clean and free of debris. Spray with brake cleaner to remove any contaminants that may have accumulated on the drive motor threads or output shaft. Use compressed air to blow away any remaining residue.
4. To ensure proper torqueing of the spider onto the motor shaft, it will be necessary to check the tightness of the spider retaining bolt using a gage block.
5. Slide gage block, Figure 6 (P/N 23380) over 2.5-inch bolt P/N 22465, and insert bolt into motor threaded shaft. Torque hand-tight to 10 ft-lbs.
6. If gage is loose, use the 2-inch bolt (P/N 20179) to mount spider assembly. If gage is tight use the 2.5-inch bolt (P/N 22465) for spider mounting.

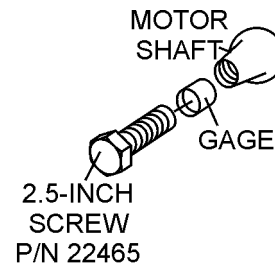

**Figure 6. 2.5-Inch Bolt With Gage**

7. Remove bolt and gage from motor shaft.
8. Lift new tapered spider assembly (keyless) onto hydraulic motor shaft. This may require two people.
9. Apply Loctite™ 271 (RED) to the selected spider retaining bolt P/N 22465 or P/N 20179 (Figure 7). Also apply RED Loctite™ to the female threads on the hydraulic motor shaft.

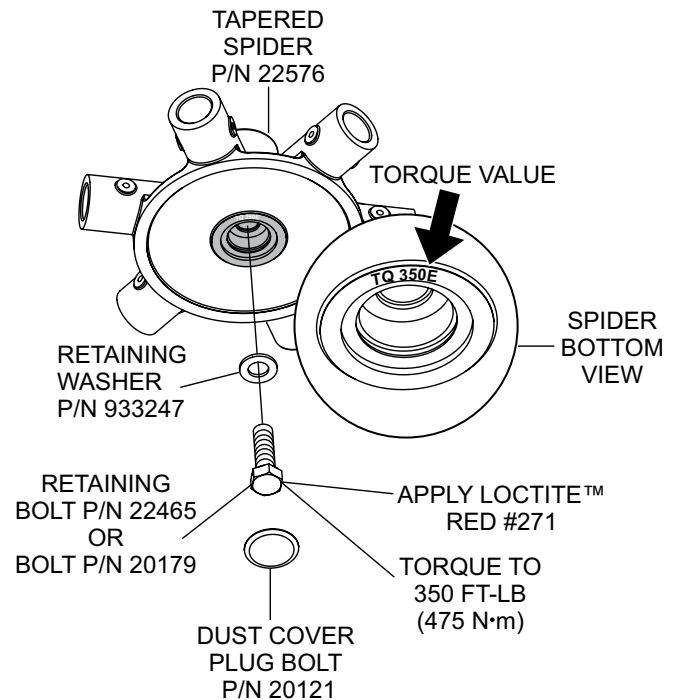

**Figure 7. Tapered Spider**

10. Place the 3/4" spider retaining washer P/N 933247 onto the spider retaining bolt and insert both items into the hydraulic motor shaft.
11. Using a torque wrench, torque spider retaining bolt to 350 ft-lb (475 N·m).
12. Remove the trowel from the jack-stands and place on a flat surface.
13. Start trowel as referenced in operator's manual. Run trowel for 15 minutes.
14. Lift and place trowel back onto jack-stands. re-torque spider retaining bolt to 350 ft-lb (475 N·m).
15. Insert snap-in spider dust cover plug.

# HERE'S HOW TO GET HELP

PLEASE HAVE THE MODEL AND SERIAL  
NUMBER ON-HAND WHEN CALLING

## UNITED STATES

### *Multiquip Corporate Office*

18910 Wilmington Ave. Tel. (800) 421-1244  
Carson, CA 90746 Fax (800) 537-3927  
Contact: mq@multiquip.com

### *Mayco Parts*

800-306-2926 Fax: 800-672-7877  
310-537-3700 Fax: 310-637-3284

### *Service Department*

800-421-1244 Fax: 310-537-4259  
310-537-3700

### *MQ Parts Department*

800-427-1244 Fax: 800-672-7877  
310-537-3700 Fax: 310-637-3284

### *Warranty Department*

800-421-1244, Ext. 279 Fax: 310-537-1173  
310-537-3700, Ext. 279

### *Technical Assistance*

800-478-1244 Fax: 310-631-5032

## MEXICO

### *MQ Cipsa*

Carr. Fed. Mexico-Puebla KM 126.5 Tel: (52) 222-225-9200  
Momoxpan, Cholula, Puebla 72760 Fax: (52) 222-285-0400  
Contact: pmastretta@cipsa.com.mx

## UNITED KINGDOM

### *Multiquip (UK) Limited Head Office*

Unit 2, Northpoint Industrial Estate, Tel: 0161 339 2223  
4100a Lane, Fax: 0161 339 3226  
Dukinfield, Cheshire SK16 4UJ  
Contact: sales@multiquip.co.uk

## CANADA

### *Multiquip*

4110 Industriel Boul. Tel: (450) 625-2244  
Laval, Quebec, Canada H7L 6V3 Tel: (877) 963-4411  
Contact: jmartin@multiquip.com Fax: (450) 625-8664

© COPYRIGHT 2010, MULTIQUIP INC.

Multiquip Inc, the MQ logo and the Whiteman logo are registered trademarks of Multiquip Inc. and may not be used, reproduced, or altered without permission. Trademarks are the property of their respective owners and used with permission.

This manual MUST accompany the equipment at all times. This manual is considered a permanent part of the equipment and should remain with the equipment.

The information and specifications included in this publication were in effect at the time of approval for printing. Illustrations, descriptions, and specifications are for guidance only and may not be considered as binding. Multiquip Inc. reserves the right to discontinue or change specifications in this publication at any time without notice and without incurring any obligations.

Your Local Dealer is:

