

OPERATION MANUAL



STX SERIES RIDE-ON POWER TROWEL STX55J6

MODEL # _____

SERIAL # _____

Revision #1(07/16/04)



MULTIQUIP INC.

18910 WILMINGTON AVE.
CARSON, CALIFORNIA 90746
310-537-3700
800-421-1244
FAX:310-537-3927

PARTS DEPARTMENT:

800-427-1244
FAX: 800-672-7877
SERVICE DEPARTMENT/TECHNICAL ASSISTANCE:
800-478-1244
FAX:310-631-5032

E-mail:mq@multiquip.com • www.multiquip.com

Atlanta • Boise • Newark
Montreal, Canada • Manchester, UK
Rio De Janeiro, Brazil • Guadalajara, Mexico



WARNING



CALIFORNIA — Proposition 65 Warning

Engine exhaust and some of its constituents, and some dust created by power sanding, sawing, grinding, drilling and other construction activities contains chemicals known to the State of California to cause cancer, birth defects and other reproductive harm. Some examples of these chemicals are:

- Lead from lead-based paints.
- Crystalline silica from bricks.
- Cement and other masonry products.
- Arsenic and chromium from chemically treated lumber.

Your risk from these exposures varies, depending on how often you do this type of work. To reduce your exposure to these chemicals: **ALWAYS** work in a well ventilated area, and work with approved safety equipment, such as dust masks that are specially designed to filter out microscopic particles.

HERE'S HOW TO GET HELP

*PLEASE HAVE THE MODEL AND SERIAL
NUMBER ON-HAND WHEN CALLING*

PARTS DEPARTMENT

800-427-1244 or 310-537-3700

FAX: 800-672-7877 or 310-637-3284

SERVICE DEPARTMENT

800-421-1244

FAX: 310-537-4259

TECHNICAL ASSISTANCE

800-478-1244

FAX: 310-631-5032

WARRANTY DEPARTMENT

888-661-4279, or 310-661-4279

FAX: 310-537-1173

STX-SERIES — TABLE OF CONTENTS

Technical Assistance	3
Table of Contents	4
Training Checklist	5
Daily Pre-Operation Checklist	6
Safety Message Alert Symbols	7-8
Rules For Safe Operation	9
Operation And Safety Decals	10
Specifications	11
General Information	12

WHITEMAN — STX-SERIES RIDE-ON POWER TROWEL

Controls and Components	13-14
Pre-Inspection	15
Initial Start-Up	16-17
Operation	18-20
Maintenance	21-26
Troubleshooting	27-28

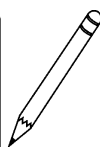
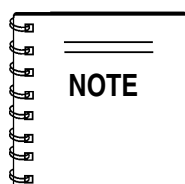

Specifications are subject to change without notice.

STX-SERIES — TRAINING CHECKLIST

TRAINING CHECKLIST

This checklist lists the minimum requirements for machine maintenance and operation. Please feel free to detach it and make copies. Use this checklist when training a new operator or use as a review for more experienced operators.

TRAINING CHECKLIST			
NO.	DESCRIPTION	OK?	DATE
1	Read Operator's Manual completely.		
2	Machine layout, location of components, checking of engine and hydraulic oil levels.		
3	Fuel system, refueling procedure.		
4	Operation of spray and lights.		
5	Operation of controls (machine not running).		
6	Safety controls, safety stop switch operation.		
7	Emergency stop procedures.		
8	Startup of machine, pre-heat, engine choke.		
9	Maintaining a hover.		
10	Maneuvering.		
11	Pitching.		
12	Matching blade pitch. Twin-Pitch™		
13	Concrete finishing techniques.		
14	Shutdown of machine.		
15	Lifting of machine (lift loops).		
16	Machine transport and storage.		

Operator _____ Trainee _____

COMMENTS:

STX-SERIES — DAILY PRE-OPERATION CHECKLIST

DAILY PRE-OPERATION CHECKLIST

DAILY PRE-OPERATION CHECKLIST		✓	✓	✓	✓	✓	✓
1	Engine oil level.						
2	Hydraulic oil level.						
3	Radiator coolant level.						
4	Condition of blades.						
5	Blade pitch operation.						
6	Safety Stop Switch operation.						
7	Steering control operation.						

COMMENTS:

STX-SERIES — SAFETY MESSAGE ALERT SYMBOLS

FOR YOUR SAFETY AND THE SAFETY OF OTHERS!

Safety precautions should be followed at all times when operating this equipment. Failure to read and understand the Safety Messages and Operating Instructions could result in injury to yourself and others.

NOTE

This Owner's Manual has been developed to provide complete instructions for the safe and efficient operation of the MQ Whiteman STX-SERIES Ride-On Power Trowel. For engine maintenance information, please refer to the engine manufacturers instructions for data relative to its safe operations.

Before using this Ride-On Power Trowel, ensure that the operating individual has read and understands all instructions in this manual.

SAFETY MESSAGE ALERT SYMBOLS

The three (3) Safety Messages shown below will inform you about potential hazards that could injure you or others. The Safety Messages specifically address the level of exposure to the operator, and are preceded by one of three words: **DANGER**, **WARNING**, or **CAUTION**.



DANGER: You **WILL** be **KILLED** or **SERIOUSLY** injured if you **DO NOT** follow directions.



WARNING: You **CAN** be **KILLED** or **SERIOUSLY** injured if you **DO NOT** follow directions.



CAUTION: You **CAN** be injured if you **DO NOT** follow directions.

Potential hazards associated with STX-SERIES Ride-on Power Trowel operation will be referenced with Hazard Symbols which appear throughout this manual, and will be referenced in conjunction with Safety Message Alert Symbols.

HAZARD SYMBOLS



Lethal Exhaust Gases



Engine exhaust gases contain poisonous carbon monoxide. This gas is colorless and odorless, and can cause death if inhaled. **NEVER** operate this equipment in a confined area or enclosed structure that does not provide ample free flow air.



Explosive Fuel

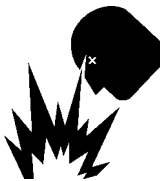

Diesel fuel is flammable, and its vapors can cause an explosion if ignited. **DO NOT** start the engine near spilled fuel or combustible fluids. **DO NOT** fill the fuel tank while the engine is running or hot. **DO NOT** overfill tank, since spilled fuel could ignite if it comes into contact with hot engine parts or sparks from the ignition system. Store fuel in approved containers, in well-ventilated areas and away from sparks and flames. **NEVER** use fuel as a cleaning agent.



Burn Hazards



Engine components can generate extreme heat. To prevent burns, **DO NOT** touch these areas while the engine is running or immediately after operations. **NEVER** operate the engine with heat shields or heat guards removed.



Rotating Parts



NEVER operate equipment with covers, or guards removed. Keep fingers, hands, hair and clothing away from all moving parts to prevent injury.



Skin Injection Hazard



NEVER use your hand to find hydraulic leaks. Use a piece of wood or cardboard. Hydraulic fluid injected into the skin must be treated by a knowledgeable physician immediately or severe injury or death can occur.

STX-SERIES — SAFETY MESSAGE ALERT SYMBOLS

! Accidental Starting

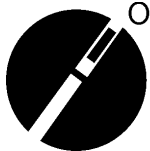

OFF **ALWAYS** place the ON/OFF switch in the OFF position, and remove the key.

! Over Speed Conditions



NEVER tamper with the factory settings of the engine governor or settings. Personal injury and damage to the engine or equipment can result if operating in speed ranges above maximum allowable.

! Respiratory Hazard

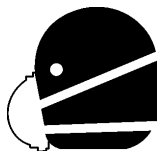

ALWAYS wear approved respiratory protection.

! Sight and Hearing hazard

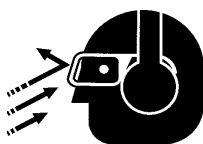

ALWAYS wear approved eye and hearing protection.

! Equipment Damage Messages

Other important messages are provided throughout this manual to help prevent damage to your trowel, other property, or the surrounding environment.

EMERGENCIES

■ **ALWAYS** know the location of the nearest **fire extinguisher**.

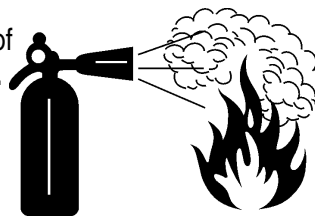

■ **ALWAYS** know the location of the nearest and **first aid kit**.



■ In emergencies **always** know the location of the nearest phone or **keep a phone on the job site**. Also know the phone numbers of the nearest **ambulance, doctor** and **fire department**. This information will be invaluable in the case of an emergency.

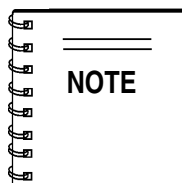
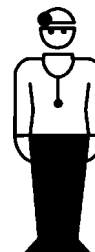

This Ride-On Power Trowel, other property, or the surrounding environment could be damaged if you do not follow instructions.

STX-SERIES — RULES FOR SAFE OPERATION

CAUTION



Failure to follow instructions in this manual may lead to serious injury or even death! This equipment is to be operated by **trained** and **qualified** personnel only! This equipment is for industrial use only and should not be regarded as a toy.

The following safety guidelines should always be used when operating the STX-SERIES Ride-on Power Trowel:

GENERAL SAFETY

- **DO NOT** operate or service this equipment before reading this entire manual.
- This equipment should not be operated by persons under 18 years of age.
- **DO NOT** operate this equipment unless all guards and safety devices are attached and in place.
- **ALWAYS** use proper **heavy** lifting techniques when moving equipment. This ride-on trowel is very heavy. It should be lifted only with a lifting device (i.e. crane, forklift, etc.) with a lifting capacity of at least one ton.
- **ALWAYS** check to make sure that the operating area is clear before starting the engine.
- **ALWAYS** test the safety **safety stop switch** before operating the equipment.
- **NEVER** place your feet inside the guard rings while starting or operating this equipment.
- **NEVER** operate this equipment without proper **protective** clothing, shatterproof glasses, steel-toed boots and other protective devices required by the job. Avoid wearing jewelry or loose fitting clothing that may snag on the controls or moving parts, this can cause a serious injury.
- **ALWAYS** keep clear of rotating or moving parts while operating this equipment.
- **NEVER** leave the machine **unattended** while running.
- **ALWAYS** refuel in a well-ventilated area, away from sparks and open flames.
- **ALWAYS** use extreme caution when working with **flammable liquids**. When refueling, **stop the** engine and allow it to cool. **DO NOT** smoke around or near the machine. Fire or explosion could result from flames or sparks, or if fuel is spilled on a hot engine.
- **Moving Parts** – Shut down the engine before performing service or maintenance functions. Contact with moving parts can cause serious injury.



■ **High Temperatures** – Allow the machine and engine to cool before adding fuel or performing service and maintenance functions. Contact with *hot* components can cause serious burns.

Maintenance Safety

- Disconnect the battery and spark plug wires before attempting any type of service.
- Securely support any machine components that must be raised.
- **NEVER** lubricate components or attempt service on a running machine.
- **ALWAYS** allow the machine a proper amount of time to cool before servicing.
- Keep the machinery in proper running condition.
- Make sure that there is no buildup of concrete, grease, oil or debris on the machine.
- Fix damage to the machine immediately and always replace broken parts.
- Dispose of hazardous waste properly. Examples of potentially hazardous waste are used motor oil, fuel and fuel filters.
- **DO NOT** use food or plastic containers to dispose of hazardous waste.
- **DO NOT** pour waste, oil or fuel directly onto the ground, down a drain or into any water source.

STX-SERIES — OPERATION AND SAFETY DECALS

OPERATION AND SAFETY DECALS

The STX-SERIES Ride-on Power Trowel is equipped with a number of operation and safety decals. These decals are provided for operator safety and maintenance information. Table 1 below illustrates these decals as they appear on the machine. Should any of these decals become unreadable, replacements can be obtained from your dealer.



P/N 35137



P/N: 13118



P/N 21589 WHITE TEXT 24" x 3"



P/N: 21455



P/N 11811
WHITE TEXT



P/N 12401

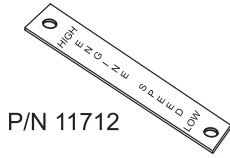

P/N 11712

STX

P/N 21579

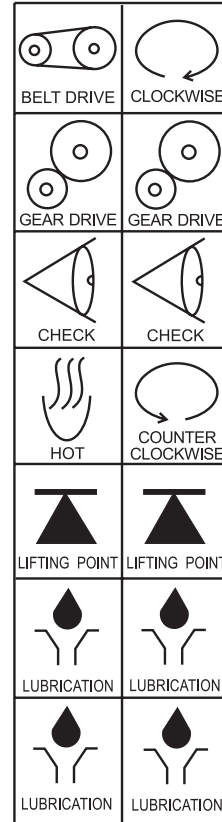

P/N 2814 (WHITE)



P/N 35168



P/N 36099 (ISO Blue)

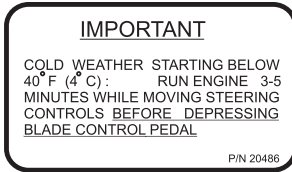

P/N 20486



CONTACT
SERVICE
DEPARTMENT



P/N 20953



P/N 20936

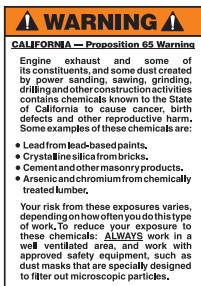

P/N 20525

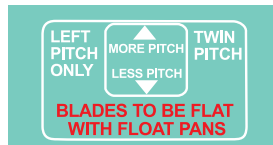

P/N 21169

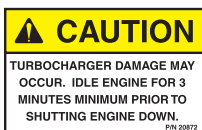

P/N 20872

TURBO

P/N 21590



P/N 21665

STX-SERIES — SPECIFICATIONS

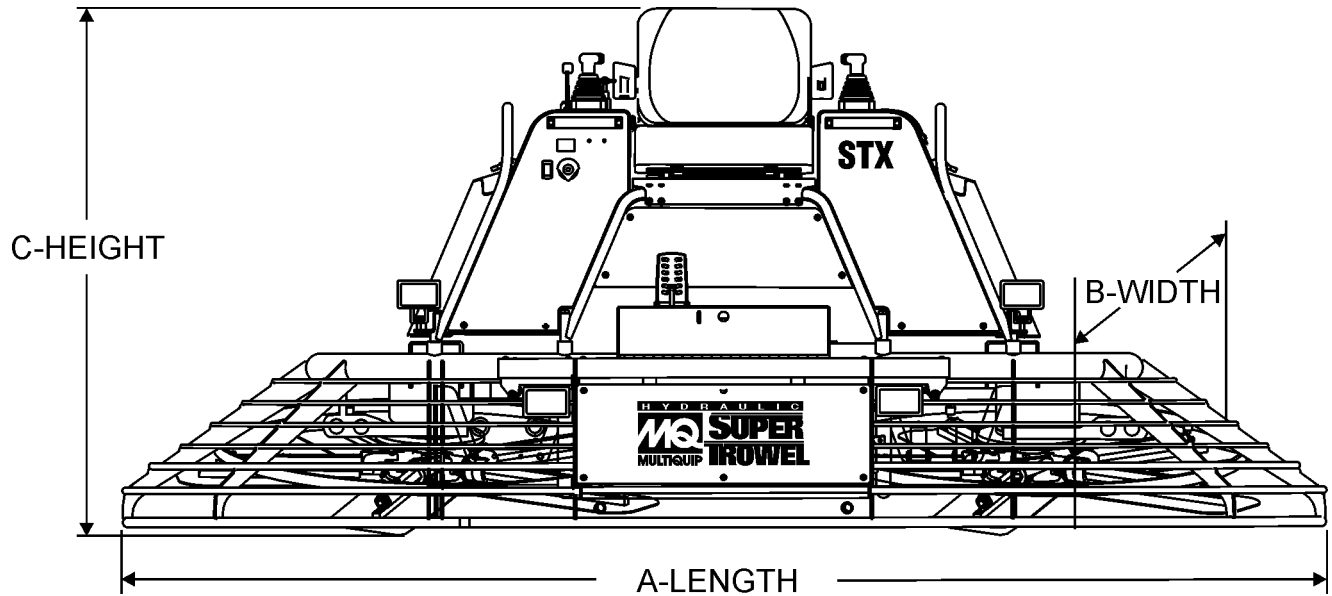

Figure 1. STX-SERIES Dimension /Specifications

Table 2. STX-Series Specifications	
STX55JDTC SL6	
A-Length – in. (cm)	125 (318)
B-Width – in. (cm)	65.0 (165)
C-Height – in. (cm) ¹	56.0 (142)
Weight – lbs. (kgs.) Operating	2,000 (909)
Weight – lbs. (kgs.) Shipping	2500 (1137)
Sound Pressure – dBA ²	97
Vibration – ft/s ² (m/ s ²) ³	<8.0 (2.5)
Blade Tip Speed – FPM (m/s)	1924 (9.9)
Engine – H.P.	55 John Deere, Diesel Turbocharged
Fuel Tank – gallons (liters)	12 (45)
Rotor – RPM	0 to 130
Path Width – in. (cm)	117 (297)
Hydraulic Oil ⁴	AW MV 68 ⁴ (10W-40 hot weather) (10W-30 cold weather)

NOTE:

1. This value includes the seat height.
2. Sound pressure is a weighted measure. Measured at the operators ear position while the ride-on trowel is operating at full throttle on concrete in a manner most often experienced in “*normal*” circumstances. Sound pressure may vary depending upon the condition of the concrete. Hearing protection is always recommended.
3. The vibration level indicated is the maximum RMS (Root Mean Square) value obtained at the handle grip while operating the ride-on trowel on curing concrete in a manner

most often experienced in “*normal*” circumstances. Values were obtained from all three axes of motion. The values shown represent the maximum RMS value from these measurements.

4. “AW” stands for *anti-wear* and “MV” stands for *multi-viscosity*. The 68 refers to the general viscosity range and is similar to 10W-30-motor oil. It is recommended that AW MV 68 hydraulic oil be used. If this type of hydraulic oil is not available then use 10W-30 engine oil (cold weather) or 10W-40 engine oil (hot weather).

STX-SERIES — GENERAL INFORMATION

GENERAL INFORMATION

The STX-SERIES Ride-On Power Trowels are designed for the floating and finishing of concrete slabs.

Take a walk around the STX-SERIES Ride-On Power Trowel. Take notice of all the entire major components (see Figures 2 and 3, pages 13 and 14) like the engine, blades, air cleaner, ignition switch etc. Check that there is always oil in the engine, and hydraulic oil in the hydraulic oil reservoir.

Read all the safety instructions carefully. Safety instructions will be found throughout this manual and on the machine. Keep all safety information in good, readable condition. Operators should be well trained on the operation and maintenance of the STX-SERIES Ride-On Power Trowel.

Before using your STX-SERIES Ride-On Power Trowel, test it on a flat watered down section of finished concrete. This trial test run will increase your confidence in using the trowel and at the same time it will familiarize you with the trowel's controls and indicators. In addition you will understand how the trowel will handle under actual conditions.

Engine

The STX-SERIES Ride-On Power Trowel is available with a standard 55hp John Deere diesel engine. Refer to the engine owner's manual for specific instructions regarding engine operation. Please contact your nearest Multiquip Dealer for a replacement should the original manual disappear or become otherwise unusable.

Blades

The blades of the Ride-on Power Trowel finish the concrete as they are swirled around the surface. Blades are classified as float (10 or 8 inches wide), and finish (6 inches wide). The STX-SERIES is equipped with six blades per rotor equally spaced in a radial pattern and attached to vertical rotating shaft by means of a *spider assembly*.

Hydraulic Motor

Independent hydrostatic drive motors are coupled to the engine-powered hydrostatic pumps. Each motor drives a spider assembly.

Hydraulic Steering

Dual palm grip joystick controls located to the left and right of the operator are provided for steering the STX-SERIES Ride-on Power Trowel. The joysticks are linked to three hydraulic steering cylinders located within the frame of the machine. Detailed explanation of how the joystick controls affect the steering of the trowel can be found in Table 3, on page 18.

Hydraulic Pump

Delivers a continuous controlled flow of hydraulic fluid to the hydraulic motors.

CAUTION

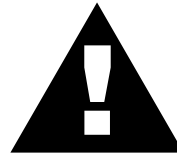

This Ride-on Power Trowel is very **heavy** and awkward to move around. Use proper heavy lifting procedures and **DO NOT** attempt to lift the Ride-on Power Trowel by the guard rings.

Moving the Ride-On Trowel

The STX-SERIES Ride-on Power Trowel is designed to be moved and handled several ways. The easiest way to lift the ride-on trowel is to utilize the lift loops that are welded to the frame. These lift loops are located to the left and right sides of the operator's seat (Figure 2, Page 13).

A strap or chain can be attached to these lift loops, allowing a forklift or crane to lift the Ride-on Power Trowel up onto a slab of concrete. The strap or chain should have a minimum 2,000 pounds (1000-kg) lifting capacity and the lifting gear must be capable of lifting at least this amount.

Training

For proper training, please use the "TRAINING CHECKLIST" located in the front of this manual (Page 5). This checklist will provide an outline for an experienced operator to provide training to a new operator.

STX-SERIES — CONTROLS AND COMPONENTS

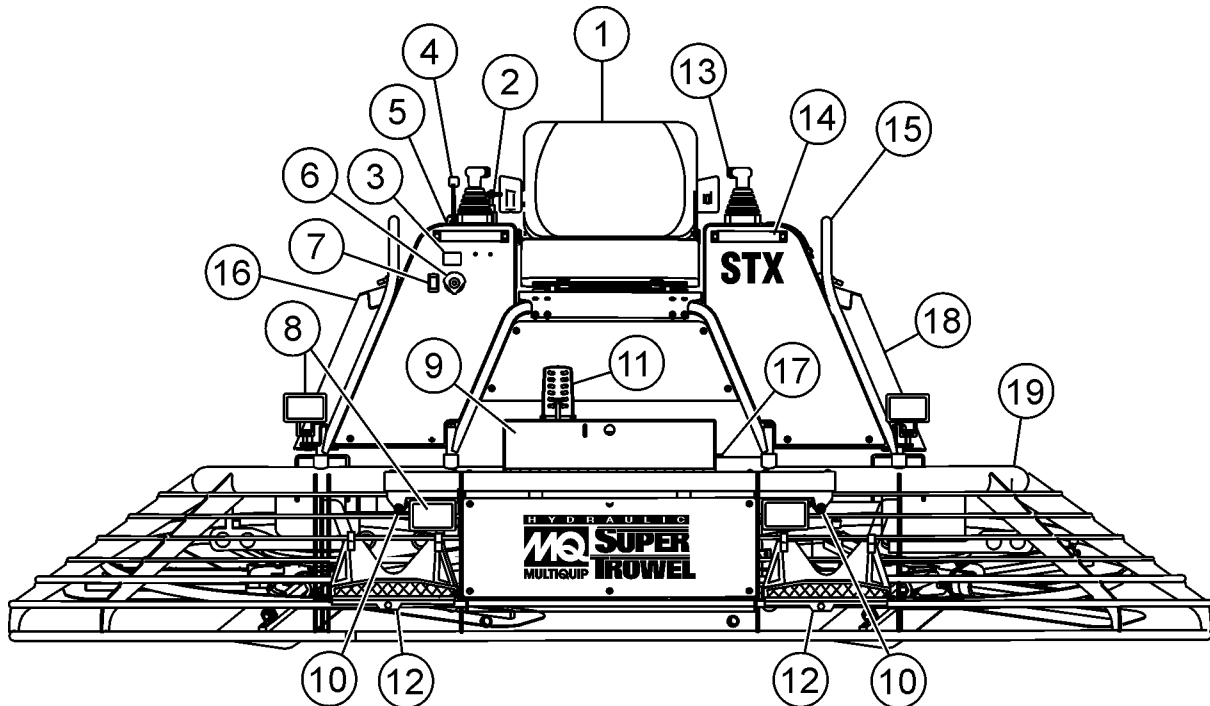

Figure 2. STX-SERIES Controls and Components (Front)

Figures 2 and 3 (pages 13 and 14) show the location of the controls, indicators and general maintenance parts. The function of each control, indicator or maintenance part is explained below:

1. **Seat** – Place for operator to sit. Trowel blades will not rotate unless operator is seated. Seat is adjustable.
2. **Trowel Speed Limiter Control** – Used to adjust the maximum trowel speed that can be obtained when the foot pedal is fully depressed.
3. **Hour Meter** – Indicates number of hours machine has been used.
4. **Throttle Control Lever** – Controls the speed of the engine. Move the hand lever forward to increase engine speed (high), backwards to decrease engine speed (low).
5. **Operator Gauges** – Allows operator to monitor engine, hydraulic and electrical functions.
6. **Ignition Switch** – With key inserted turn clockwise to start engine.
7. **Light Switch** – When activated, turns on six halogen lights. Lights offer better visibility when working indoors.
8. **Lights** – Six low voltage halogen lights are provided with this unit.
9. **Toolbox Compartment** – Storage for tools.
10. **Spray Nozzles** – Spray nozzle for retardant. Two spray nozzles are supplied with this unit.
11. **Foot Pedal** – Controls blade speed. Slow blade speed is accomplished by slightly depressing the foot pedal. Maximum blade speed is accomplished by fully depressing the foot pedal.
12. **Removable Steps (left & right)** – Provides for safe footing for mounting and dismounting trowel. When removed, provides access to spider and blade assemblies.
13. **Retardant Spray Control Buttons (left & right)** – When pressed allows retardant spray to flow through the spray nozzle located at the front of the machine.
14. **Hand Holds** – Use to assist safe mounting and dismounting trowel.
15. **Lift Loops** – Located on both the left and right sides of the main frame. Used when the trowel must be lifted onto a concrete slab.
16. **Pitch Block** – (Behind grill guard.) Measure and adjust pitch pressure at the pitch block.
17. **Fuel Gauge/Filler Cap** – Indicates the amount of fuel in the fuel tank. Remove this cap to add fuel.
18. **Overflow Bottle** – (Behind grill guard.) Supplies water or coolant to the radiator when radiator water or coolant level is low. Fill to indicated level as shown on bottle.
19. **Hydraulic Reservoir** – Part of frame. Holds hydraulic oil necessary for pump operation.

STX-SERIES — CONTROLS AND COMPONENTS

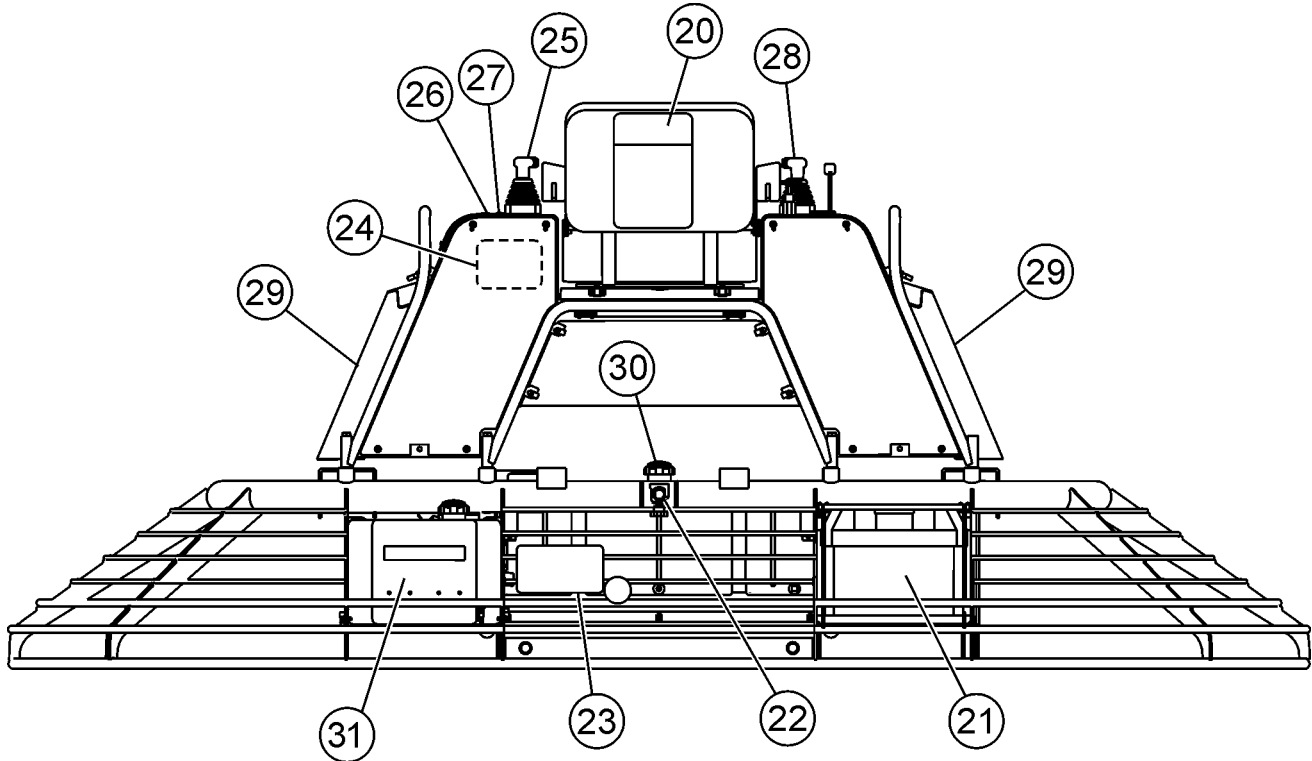
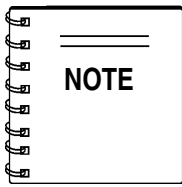

Figure 3. STX-SERIES Controls and Components (Rear)

20. **Documentation Box** – Storage for documentation and other information regarding the trowel.
21. **Battery** – Provides +12V DC power to the electrical system.
22. **Hydraulic Oil Sight Glass** – Indicates the level of the hydraulic oil in the reservoir.
23. **Hydraulic Suction Filter** – Filters hydraulic fluid prior to entering the system. (10 Micron absolute synthetic media.)
24. **Hydraulic Oil Expansion Tank** – Accommodates expanding hydraulic oil as it gets hot. The oil gravity flows back to the reservoir as it cools down, therefore **NEVER** open the the Hydraulic Oil Filler Cap (Item 30) when the system is warm and the oil has expanded.
25. **Steering Control (left side)** – Allows the unit to move in a forward or reverse direction only.
26. **Blade Pitch Control Switch (left side)** – Adjusts the left side blade pitch independently of the right side.
27. **Blade Pitch Control (Twin Pitch)** – Adjusts the blade pitches simultaneously.
28. **Steering Control (right side)** – Allows the unit to move in either a forward, reverse left or right direction.
29. **Grill Guards (left & right)** – Protects operator from moving components. Remove for maintenance access.
30. **Hydraulic Oil Filler Cap** – Remove this cap to add hydraulic oil. Open **ONLY** when system is cooled down and all expanded oil has returned to the reservoir.
31. **Retardant Spray Tank** – Holds 5 gallons of retardant, water, or other liquid.

STX-SERIES — PRE-INSPECTION

PRE-INSPECTION



The following sections are intended to assist the operator with pre-inspection and the initial start-up of the STX-SERIES Ride-On Power Trowel. It is extremely important that these sections are read carefully before attempting to use the trowel

in the field. **DO NOT** use your Ride-On Power Trowel until these sections are thoroughly understood.

CAUTION



Failure to understand the operation of the STX-SERIES Ride-On Power Trowel could result in severe damage to the trowel or personal injury.

See Figures 2 and 3 (Pages 13 and 14) for the location of controls and indicators referenced in this manual.

Engine Oil

1. Pull the engine oil dipstick from its holder.
2. Determine if engine oil is low (Figure 4), add correct amount of engine oil to bring oil level to a normal safe level.

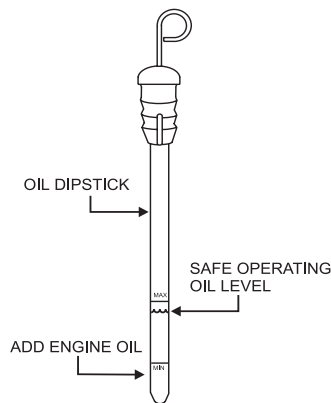

Figure 4. Engine Oil Dipstick

Hydraulic Oil

Determine if the hydraulic oil is low by observing the level of oil in the hydraulic Oil Sight Glass (Figure 5). The hydraulic tank has an elevated overflow bottle. **DO NOT** remove the fill cap when the oil is hot or spillage will occur.

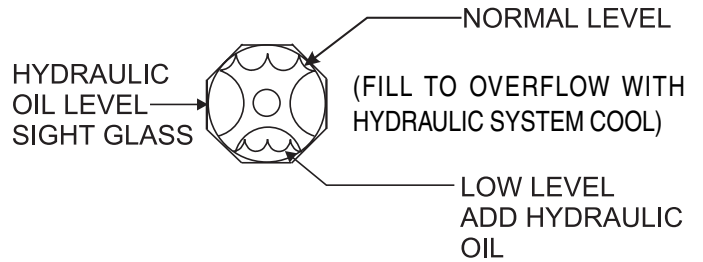

Figure 5. Hydraulic Oil Sight Glass

CAUTION



Hydraulic oil can get **HOT!**

ALWAYS allow hydraulic oil to cool before removing fill cap.

CAUTION



Removal of the fill cap when oil fills the sight glass will cause hydraulic oil to spill. Clean up hydraulic oil spills immediately.

Fuel

Determine if the engine fuel is low (Figure 6). If fuel level is low, remove the fuel filler cap and fill with diesel fuel. Handle fuel safely. Motor fuels are highly flammable and can be dangerous if mishandled. **DO NOT** smoke while refueling. **DO NOT** attempt to refuel the ride-on trowel if the engine is hot or running.

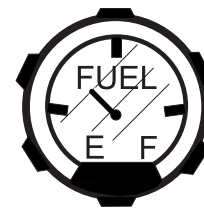
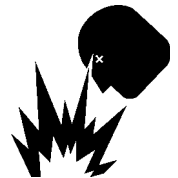

Figure 6. Fuel Gauge

CAUTION



NEVER store the Ride-On Power Trowel with fuel in the tank for any extended period of time. **ALWAYS** clean up spilled fuel immediately.

INITIAL START-UP

CAUTION



NEVER operate the trowel in a confined area or enclosed area structure that does not provide ample free flow of air.



ALWAYS wear approved eye and hearing protection before operating the ride-on power trowel.

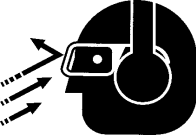

NEVER place hands or feet inside the guard rings while the engine is running. **ALWAYS** shut the engine down before performing any kind of maintenance service on the trowel.



Starting the Engine

1. With one foot on the ground and the other foot placed on the trowel's platform, grasp the grab handles lifting yourself onto the trowel. Then sit down in the operator's seat.

CAUTION



DO NOT grab hold of the joysticks to lift yourself onto the trowel. Pulling on the joysticks repeatedly will weaken the units. Always use the grab handles to lift yourself on the trowel.

2. The STX Ride-On Power Trowel is equipped with a **Safety Stop Switch**. The trowel will not move unless an operator is sitting in the seat. While the engine can be started or continue to run with the operator off the seat, the rotors will not rotate. The weight of an operator activates a switch within the seat allowing the rotors to turn.

CAUTION

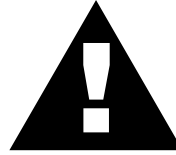

NEVER disable or disconnect the **Safety Stop Switch**. It is provided for the operators' safety and injury may result if it is disabled, disconnected or improperly maintained.

3. It is recommended that the operation of the **Safety Stop Switch** is checked prior to performing any troweling operations. Doing this will verify that the switch is working properly and presents no danger to the operator.
4. Place the **engine throttle lever** (Figure 7) in the **LOW** position.

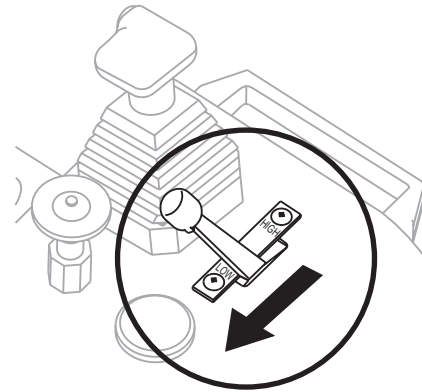

Figure 7. Engine Throttle Control Lever (Low)

5. Insert the **ignition key** into the ignition switch (Figure 8).

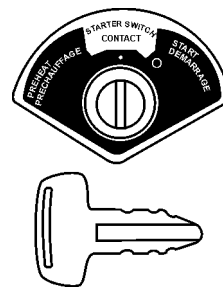

Figure 8. Ignition Switch and Key

6. Turn the ignition key clockwise to the (start) position. The **oil** and **charge** indicator lights (Figure 9) should be on.

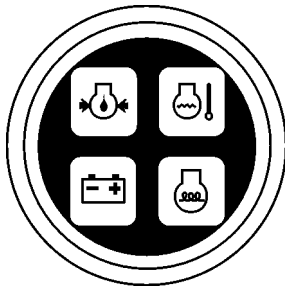

Figure 9. Oil and Charge Indicator Lights

NOTE

In **cold** weather turn and hold the ignition key counter clockwise to the preheat position, wait until the preheat indicator goes off before turning the ignition key clockwise to the start position. Two or three preheat cycles may be necessary in very cold weather.

7. Turn ignition key fully clockwise and listen for engine to start. Once engine has started release ignition key. Let engine warm for a few minutes.
8. Place the **engine throttle lever** (Figure 11) in the **HIGH** position.
9. The engine should be running at full RPM.
10. Repeat this section a few times to get fully acquainted with the engine starting procedure.

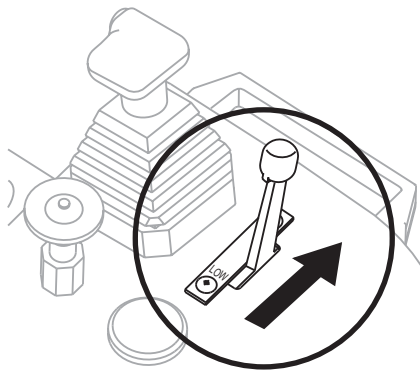
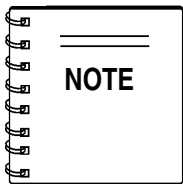

Figure 10. Engine Throttle Control Lever (High)

STX-SERIES — OPERATION

OPERATION



The following section is intended as a basic guide to the Ride-On Power Trowel operation, and is not to be considered a complete guide to concrete finishing. It is strongly suggested that all operators (experienced and novice) read "*Slabs on Grade*" published by the American Concrete Institute, Detroit Michigan.

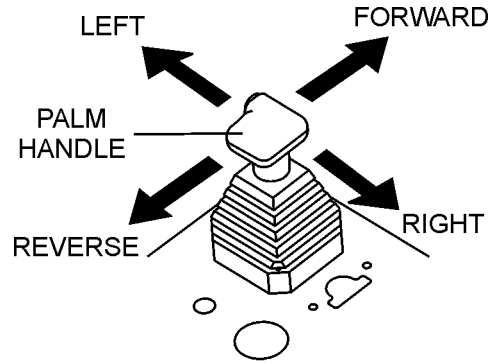

RIGHT JOYSTICK CONTROL

Figure 12. Right Joystick Control

See Table 3 for steering and directional relationship to Joystick Control movement.

Steering

Two joysticks (Figures 11 and 12) located to the left and right of the operator's seat provide directional control for the STX-SERIES Ride-On Power Trowel. Table 3 illustrates the various directional positions of the joysticks and their effect on the ride-on trowel.

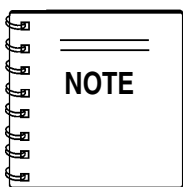

All directional references with respect to the joysticks are from the **operator's** seat position.

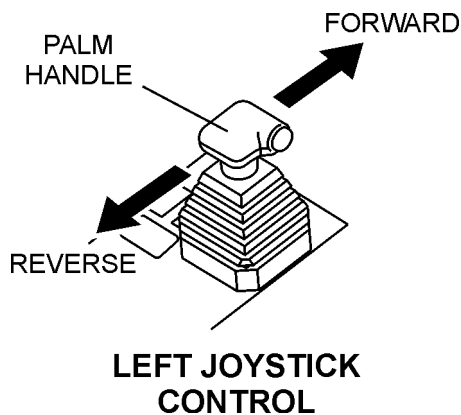

LEFT JOYSTICK CONTROL

Figure 11. Left Joystick Control

Table 3. Joystick Directional Positioning	
JOYSTICK & DIRECTION	RESULTS
Move LEFT Joystick Forward ↑	Causes only the left side of the ride-on trowel to move forward.
Move LEFT Joystick Backward ↓	Causes only the left side of the ride-on trowel to move backward.
Move RIGHT Joystick Forward ↑	Causes only the right side of the ride-on trowel to move forward.
Move RIGHT Joystick Backward ↓	Causes only the right side of the ride-on trowel to move backward.
Move BOTH Joysticks Forward ↑ ↑	Causes the ride-on trowel to move forward in a straight line.
Move BOTH Joysticks Backward ↓ ↓	Causes the ride-on trowel to move backward in a straight line.
Move RIGHT Joystick to the Right →	Causes the ride-on trowel to move to the right.
Move RIGHT Joystick to the Left ←	Causes the ride-on trowel to move to the left.

1. The foot pedal (Figure 13) solely controls blade speed. The position of the foot pedal determines the blade speed. Slow blade speed is obtained by slightly depressing the pedal. Maximum blade speed is obtained by fully depressing the pedal.

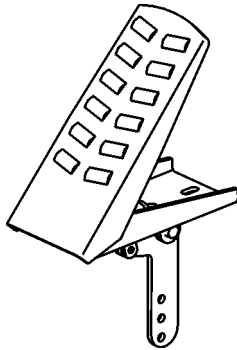

Figure 13. Blade Speed Control Foot Pedal

2. Push both the left and right joysticks forward (Figure 14).

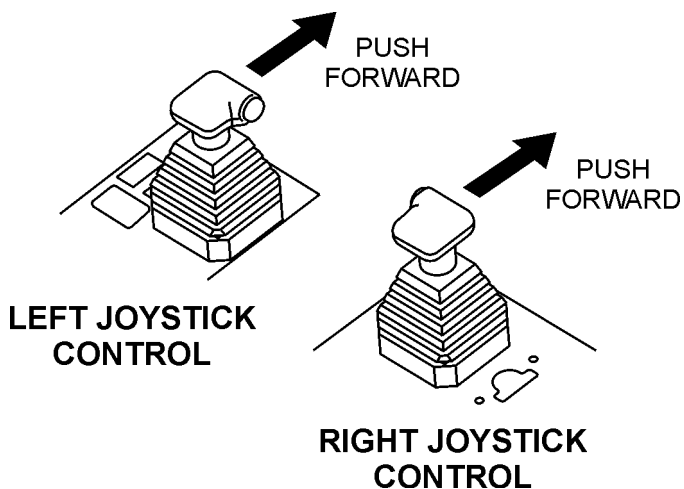

Figure 14. Joystick Control Forward Direction

3. With your right foot, slowly depress the right foot pedal halfway. Notice that the ride-on power trowel begins to move in a forward direction. Release both joystick controls to stop forward movement then remove your right foot from the foot pedal.
4. Practice holding the machine in one place as you increase blade speed. When about 75% of maximum blade speed has been reached, the blade will be moving at proper finishing speed. The machine may be difficult to keep in one place. Trying to keep the ride-on trowel stationary is a good practice for operation.

5. Practice maneuvering the Ride-on Power Trowel using the information listed in Table 3. Try to practice controlled motions as if you were finishing a slab of concrete. Practice edging and covering a large area
6. Try adjusting the pitch of the blades. This can be done with the ride-on trowel stopped or while the trowel is moving, whatever feels comfortable. Test the operation of optional equipment like retardant spray and lights if equipped.
7. Pull both the left and right joysticks backward (Figure 15) and repeat steps 3 through 6 while substituting the word reverse for forward.

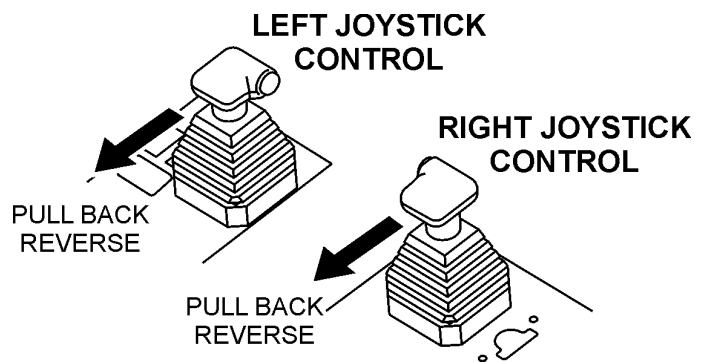

Figure 15. Joystick Control Reverse Direction

Trowel Speed Limiter Control

The speed limiter control located on the control panel (Figure 16) can be used to adjust the maximum trowel speed that can be obtained when the foot pedal is fully depressed. Pull up to reduce the maximum speed and push down to return to full speed. For fine adjustments, rotate the knob clockwise or counter-clockwise.

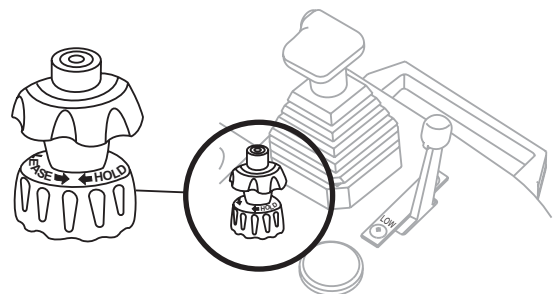

Figure 16. Trowel Speed Limiter Control

Blade Pitch Control

The trowel blades can be pitched for various finishing operations with the two rocker switches located on the left control panel next to the left joystick control (Figure 17).

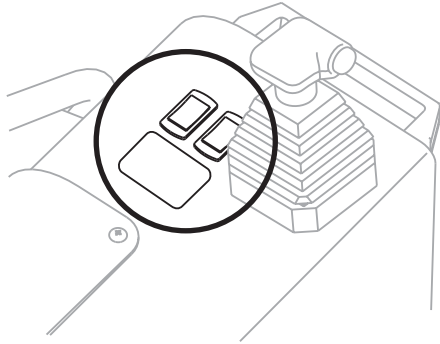

Figure 17. Blade Pitch Control

The right switch pitches both blades at the same time while the left switch will pitch only the left blade. Moving the switches forward increases the pitch while moving them backward decreases the pitch, (Figure 18).

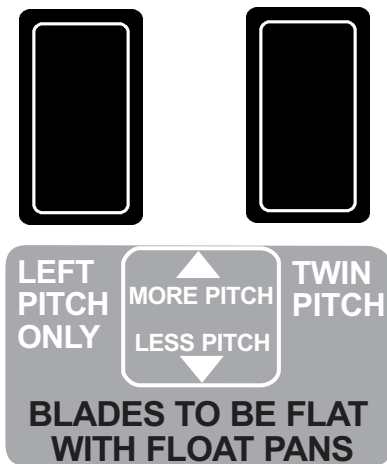

Figure 18. Blade Pitch Rocker Switches

Important! To get the blades absolutely flat for using float pans follow these steps:

1. **TWIN PITCH** all the way **DOWN**.
2. **LEFT PITCH** up a little ways.
3. **TWIN PITCH** all the way **DOWN**, again.
4. **LEFT PITCH** all the way **DOWN**.

Engine Shut-Down

1. Return the speed control lever (Figure 19) to low idle, and allow the engine to idle for 5 minutes .

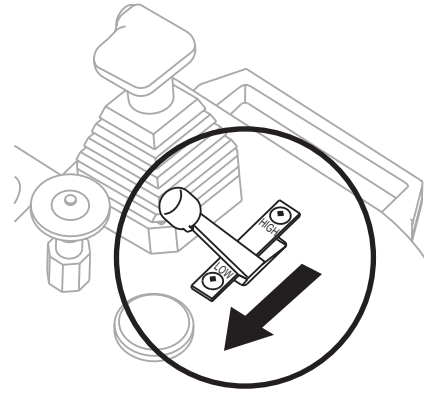
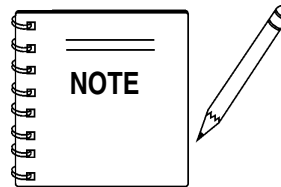

Figure 19. Blade Pitch Control



Failure to allow the engine to idle for 5 minutes before shutting engine **OFF** may lead to turbocharger damage.

2. Turn the ignition key counter-clockwise to the "**starter switch contact**" position, then remove the key.
3. Clean and remove any foreign debris from the trowel.

MAINTENANCE

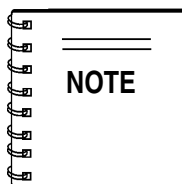

See the engine manual supplied with your machine for appropriate engine maintenance schedule and troubleshooting guide for problems.

At the front of the book (Page 6) there is a “Daily Pre-Operation Checklist”. Make copies of this checklist and use it on a daily basis.

CAUTION



Disconnect battery cables before attempting any service or maintenance on the Ride-on Power Trowel. **ALWAYS** allow the engine to cool before servicing. **NEVER** attempt any maintenance work on a hot! (muffler, radiator, etc.) trowel.



Maintenance Schedule

Change the **hydraulic oil** and **filter** after the first 100 hours of use, then change every 250 hours.

Daily (8-10 Hours)

1. Check fluid levels in engine and reservoir; fill as necessary. Weekly (30-40 Hours)
2. Relube arms, thrust collar and clutch.
3. Replace blades if necessary.
4. Check, clean, or replace the engine air filter as necessary.
5. Replace engine oil and filter as necessary, see engine manual.

Monthly (100-125 Hours)

Remove, clean, reinstall and relube the arms and thrust collar. Adjust the blade arms.

Yearly (500-600 Hours)

1. Check and replace if necessary the arm bushings, and thrust collar bushings.
2. Adjust blade speed.
3. Replace hydraulic fluid and hydraulic filter.

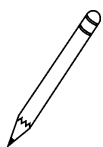
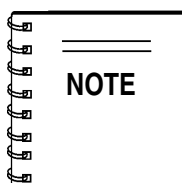

Change the **hydraulic oil** and **filter** after the first 100 hours of use, then change every 250 hours.

MAINTENANCE PROCEDURES

Checking/Adjusting Trowel Speed

Because the two hydraulic drive motors operate independent of each other, the trowel speed between them may vary. If the unit's steering is difficult to control, or if one spider is spinning noticeably faster or slower than the other, the trowel speed may need to be checked. It is also recommended that the trowel speed be checked at least once a year.

Trowel speed adjustment is a two-step process. First, the left side should be checked and/or adjusted. Second, the right side should be adjusted to match the left.

Left Side Trowel Speed Adjustment

The left side trowel speed is adjusted by the set bolt located under the operator's platform (Item A, Figure 20) and accessed by opening the storage panel door. Backing the set screw out decreases the left side trowel speed; screwing it inward increases the speed.

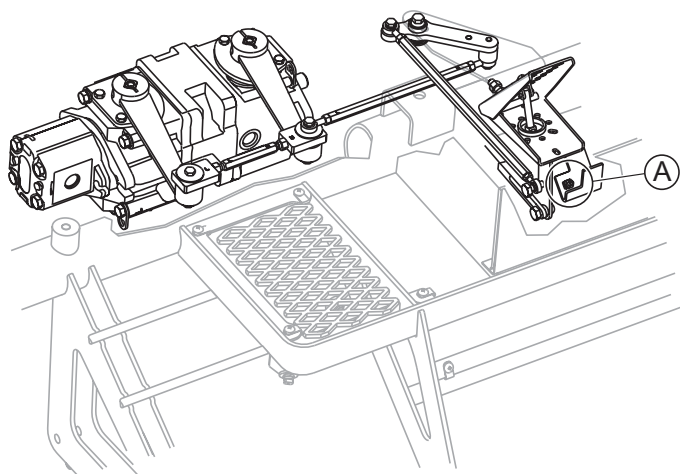

Figure 20. Trowel Speed Control

Right Side Trowel Speed Adjustment

The right side trowel speed is adjusted by changing the length of the connecting rod on the pump actuation levers (Figure 21).

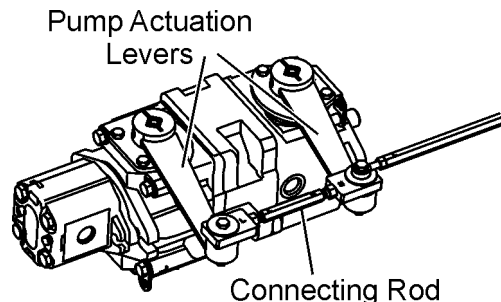

Figure 21. Pump Connecting Rod & Levers

This rod is basically a turnbuckle (Figure 22). Rotating it in one direction increases the length and corresponding trowel speed. Rotating it the opposite direction decreases the length and trowel speed. The right side trowel speed should be within 3 rpm of the left.

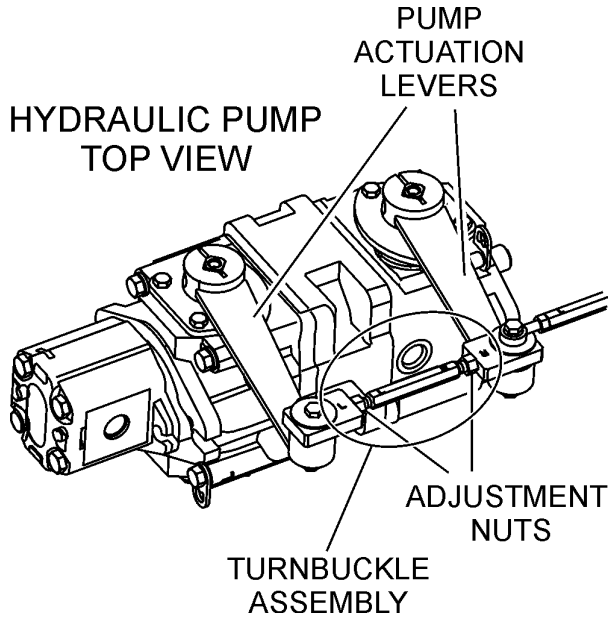

Figure 22. Turnbuckle & Adjustment Nuts

A good starting point in the adjustment process is to adjust the rod such that both trowels begin to rotate at the same time when the foot pedal is slowly depressed. This will, generally, get the speeds fairly close; close enough for use if instrumentation is unavailable (i.e. on the job site). From this point on, some form of instrumentation is required to verify that the trowel speeds are within tolerance. A strobe or magnetic pickup type speed indicator is recommended to verify the speeds.

The trowel speeds should be adjusted on a dry concrete floor with the blades pitched flat. Units with the John Deere turbocharged engine should be set at 130-135 RPM with the engine at full speed.

Matching Blade Pitch for Both Sets of Blades

Sometimes it may be necessary to match blade pitch between the left and right sets of blades. There are some signs that this may be necessary. For example, the differences in pitch can cause a noticeable difference in finish quality between the left and right sets of blades. The difference in blade pitch can also make the machine difficult to control. This is due to the surface area in contact with the concrete (the blade set with the greater contact area tends to stick to the concrete more).

To synchronize pitch on both sides, the left blade assembly can be pitched by itself. By using the electric blade pitch rocker switches, (Figure 23) the pitch can be synchronized on the left and the right sides.

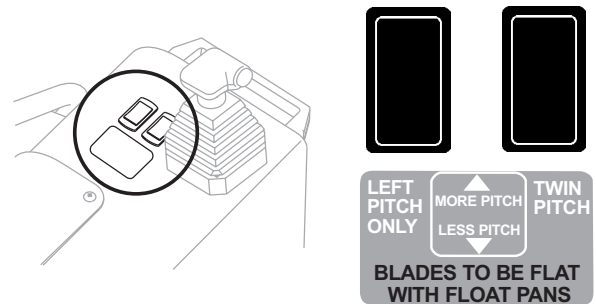

Figure 23. Blade Pitch Rocker Switches

Blade Pitch Adjustment Procedure

The maintenance adjustment of blade pitch is an adjustment that is made by a bolt (Figure 24) on the arm of the trowel blade finger. This bolt is the contact point of the trowel arm to the lower wear plate on the thrust collar. The goal of adjustment is to promote consistent blade pitch and finishing quality.

Watch for the following indications when determining if blade pitch adjustments are necessary:

- Is the machine wearing out blades unevenly (i.e. one blade is completely worn out while the others look new)?
- Does the machine have a perceptible rolling or bouncing motion when in use?
- Look at the machine while it is running, do the guard rings “rock up and down” relative to the ground?

Adjustments are made by tightening or loosening the blade pitch adjustment bolt (Figure 24).

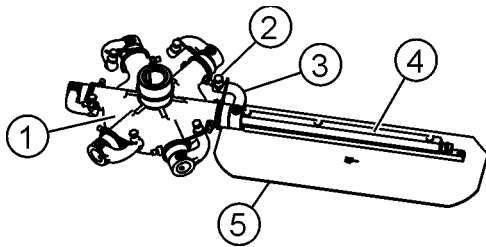

Figure 24. Blade Pitch Adjustment Bolt

1. Spider Plate
2. Blade Pitch Adjustment Bolt
3. Trowel Lever
4. Trowel Arm
5. Trowel Blade

The easiest and most consistent way to make this adjustment is to use the Trowel Arm Adjustment Fixture (P.N. 9177) that is manufactured by Whiteman Industries. This fixture will allow consistent adjustment of the trowel arm fingers. It comes with all the hardware necessary to properly accomplish this maintenance and instructions on how to properly utilize this tool. Adjusting the trowel arm fingers without a fixture requires a special talent.

If a trowel arm adjustment fixture is not available and immediate adjustment is necessary; we suggest the following procedure. If you can see or feel which blade is pulling harder, adjust the bolt that corresponds to that blade. Another way to determine which blades need adjustment is to place the machine on a flat surface and pitch the blades as flat as possible. Now, look at the adjustment bolts. They should all barely make contact with the lower wear plate on the spider. If you can see that one of them is not making contact; some adjustment will be necessary.

It will be possible to adjust the “high” bolts down to the level of the one that is not touching, or adjust the “low” bolt up to the level of the higher ones. If possible, adjust the low bolt up to the level of the rest of the bolts. This is the fastest way, but may not always work. Verify that after adjustment, the blades pitch correctly. Often times, if the blades are incorrectly adjusted, they will not be able to pitch flat. This occurs when the adjusting bolts have been raised too high. Conversely, sometimes the adjusting bolts are too low and the blades cannot be pitched high enough for finishing operations.

Changing A Blade

It is recommended that all the blades on the entire machine are changed at the same time. If only one or some of the blades are changed at one time, the machine will not finish concrete consistently and the machine may wobble or bounce.

1. Place the machine on a flat, level surface. Adjust the blade pitch control to make the blades as flat as possible. Note the blade orientation on the trowel arm. This is important for ride-on trowels as the two sets of blades counter-rotate. Lift the machine up, placing blocks under the main guard ring to support it.
2. Remove the bolts and lock washers on the trowel arm, and then remove the blade. (Access is easier if the steps are removed.)
3. Scrape all concrete and debris from the trowel arm. This is important to properly seat the new blade.
4. Install the new blade, maintaining the proper orientation for direction of rotation.
5. Affix the bolts and lock washers.
6. Torque to 9 ft. lbs.
7. Repeat steps 2-6 for all remaining blades.

STX-SERIES — MAINTENANCE

Checking Hydraulic Pressure

Many hydraulic problems are a result of low fluid levels. Before checking any other possibilities, make sure the hydraulic fluid level is up to the top of the sight glass which is located at the back/center of the frame.

Hydrostatic pressure can be checked using a pressure gauge with a range of at least 5,000 psi. Two male diagnostic quick couplers (one for each pump) are located beneath the right grill guard. To access couplers (Item B, Figure 26), remove the grill guard. It is best to use two gauges simultaneously (Figure 25), but it is possible to use only one gauge and repeat the procedure for each side.

To fully test the hydrostatic system, the spiders will need to be locked so that they cannot rotate. This can be done by wrapping a chain around an arm on each spider, thus chaining them together in the back of the trowel.

Once the pressure gauges are installed and the spiders chained together, the system can be checked.

With the foot pedal in the idle position and the engine at full speed, the pressure should be 200 to 300 psi. If the pressure is less than 200 psi, the charge system may need to be inspected and/ or serviced. In particular, the suction filter and charge pump relief valve should be checked. The suction filter may be plugged, or the relief valve may be stuck. Either condition may cause low charge pressure.

With the engine at 50% to 70% of full speed, and spiders chained together, slowly depress the foot pedal and read the gauges. The pressure should get to at least 4,350 psi (300 bar). If the pressure will not attain 4,350 psi (300 bar), the pump should be inspected and/or serviced by an authorized service representative.

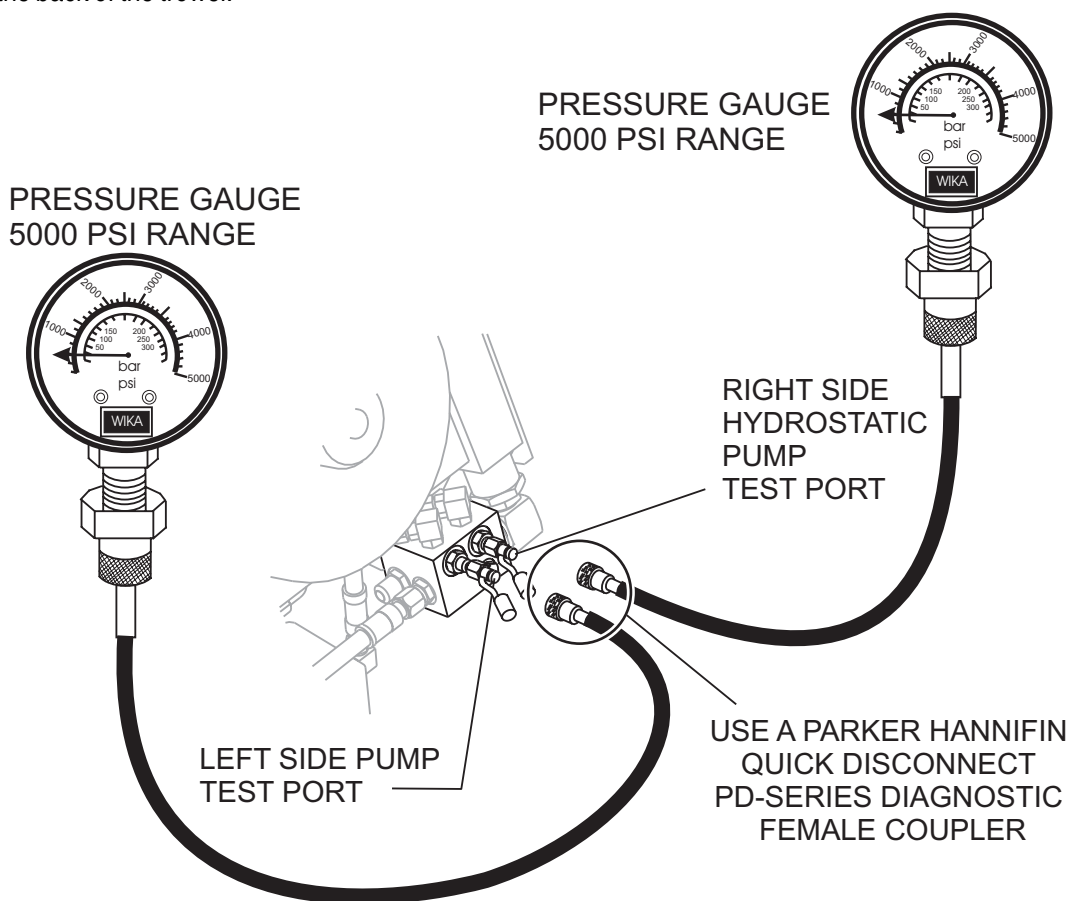

Figure 25. Pressure Gauge (Hydraulic Pump)

Checking Steering Pressure

Steering pressure is also checked at either of the high pressure diagnostic couplers under the right grill guard. Check steering pressure at either coupler with a 300-600 PSI gauge.

CAUTION



DO NOT depress the FOOT PEDAL with the 300-600 PSI gauge installed or the gauge will be ruined.

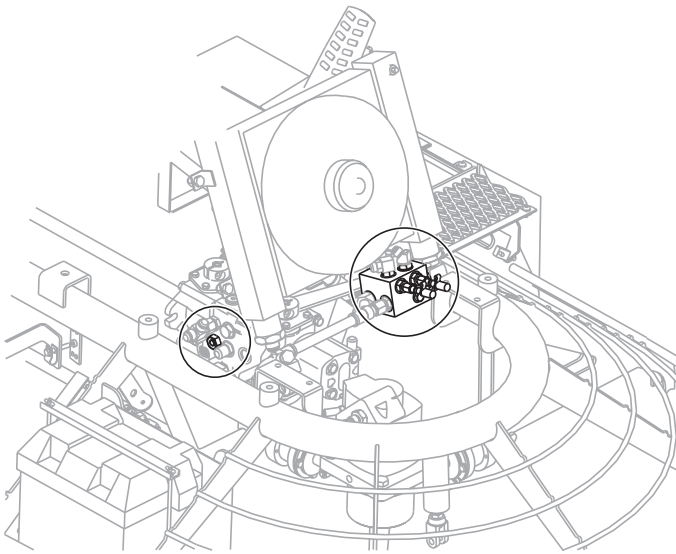

Figure 26. Pressure Check Couplers

PRESSURE GAUGE
300-600 PSI RANGE

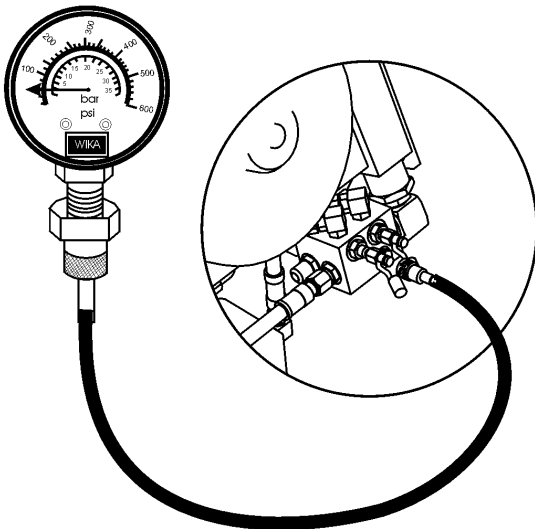

Figure 27. Steering Pressure Check

(Table 4) indicates proper steering pressure. Check with engine at Full Speed.

Table 4. Steering Pressure	
Checked With Engine at Full Speed	
Cool Oil	200-250 PSI
Hot Oil	180-200 PSI

Run the engine at full RPM. The steering system's factory setting is as shown in Table 4, however some operators may prefer a more responsive steering (higher pressure required) and some operators may prefer a "softer feel" (lower pressure required).

Steering Pressure Adjustment

Remember, **DO NOT** depress the foot pedal with the 300-600 PSI gauge installed. Immediate damage to the gauge will occur.

1. Remove right grill guard.
2. Install 300 or 600 PSI gauge (Figure 27).
3. Loosen 1-1/16" jam nut on charge relief valve (Item A, Figure 28).
4. Use a 1/2" socket to adjust the small hex nut within the larger hex jam nut (Item B, Figure 28).
5. Adjust to proper steering pressure specifications shown in Table 4.
6. Retighten jam nut, remove gauge, and reinstall grill guard.

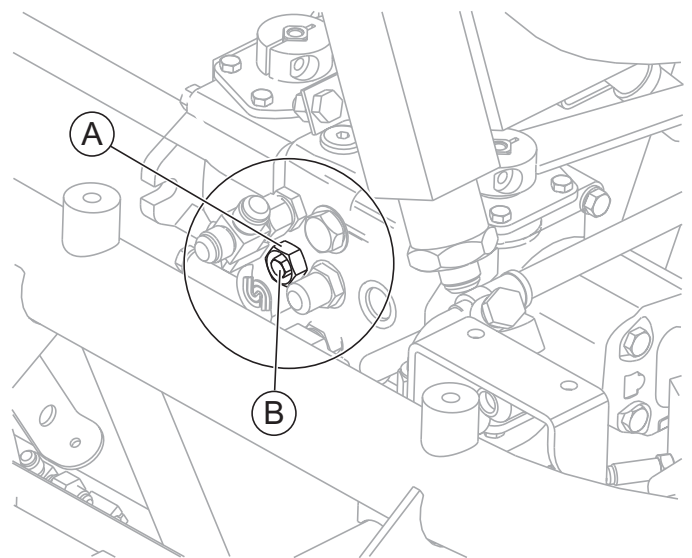

Figure 28. Steering Pressure Adjustment

Pitch Pressure Check

Access the pitch block and pitch pressure test port at the right-rear of the trowel (Figure 29). Removal of the right-rear seat frame panel may be necessary. Pitch pressure must be measured with a pitch switch **activated**. With pitch switches unactivated, the pitch pressure will be the same as the charge/steering pressure. Proper pitch pressure is 2300 PSI.

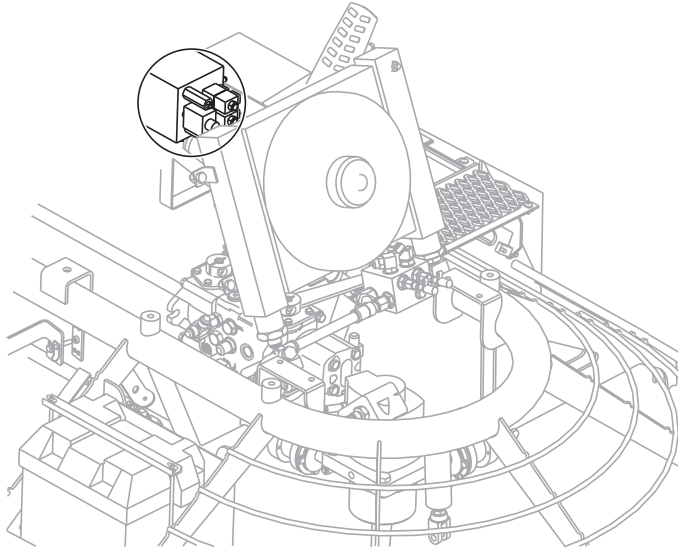

Figure 29. Pitch Block

1. Install 3000 PSI range pressure gauge to pitch pressure test port on pitch block (Figure 30).
2. Activate left pitch switch.
3. Flatten blades (bottom out the pitch cylinders).
4. Continue to hold down pitch switch and record pressure.

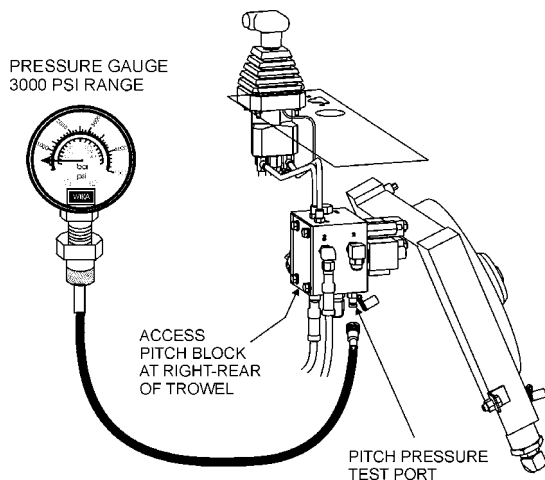

Figure 30. Pitch Pressure Check

Pitch Pressure Adjustment

If the pitch pressure check is out of specification, check the following:

1. Correct hydraulic fluid level.
2. Plugged hydraulic oil filter.
3. Loose or leaky fittings
4. Ruptured/damaged hydraulic lines.
5. Faulty hydraulic pump.
6. Pitch pressure Relief Valve no longer at factory setting.

The Pitch Pressure Relief Valve is SET AT THE FACTORY, and normally should require no adjustment. If all other systems are found not to be defective and the pitch relief valve is suspect, (loosened jam nut for example), the following steps can be used to adjust the valve.

CAUTION

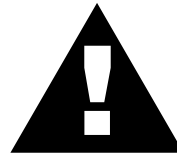

NEVER allow the pitch pressure to exceed 2700 PSI or equipment damage may result.

1. Remove right grill guard and right rear seat frame panel.
2. Install 3000 PSI pressure gauge to pitch pressure test port on pitch block (Figure 30).
3. Loosen jam nut on pitch block relief valve (Item A, Figure 31).
4. Adjust the relief valve (Item B, Figure 31) with allen wrench to proper pressure (2300 PSI)
5. Tighten jam nut, remove gauge and reinstall grill guard and frame panel.

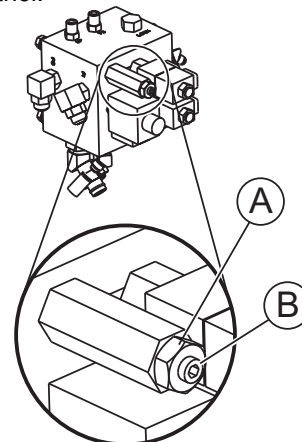

Figure 31. Pitch Pressure Adjustment

STX-SERIES — TROUBLESHOOTING

TABLE 5. TROUBLESHOOTING

SYMPTOM	POSSIBLE PROBLEM	SOLUTION
Engine running rough or not at all.	Fuel?	Look at the fuel system. Make sure there is fuel being supplied to the engine. Check to ensure that the fuel filter is not clogged.
	Ignition?	Check to ensure that the ignition switch has power and is functioning correctly.
Safety Stop Switch not functioning.	Other problems?	Consult engine manufacturer's manual.
	Loose wire connections?	Check wiring. Replace as necessary.
	Bad contacts?	Replace seat cushion (contains the switch).
If trowel "bounces, rolls concrete, or makes uneven swirls in concrete".	Blades?	Make certain blades are in good condition, not excessively worn. Finish blades should measure no less than 2" (50mm) from the blade bar to the trailing edge, combo blades should measure no less than 3.5" (89mm). Trailing edge of blade should be straight and parallel to the blade bar.
	Spider?	Check that all blades are set at the same pitch angle as measured at the spider. A field adjustment tool is available for height adjustment of the trowel arms (see Optional Equipment).
	Bent trowel arms?	Check the spider assembly for bent trowel arms. If one of the arms is even slightly bent, replace it immediately.
	Trowel arm bushings?	Check the trowel arm bushings for tightness. This can be done by moving the trowel arms up and down. If there is more than 1/8" (3.2 mm) of travel at the tip of the arm, the bushings should be replaced. All bushings should be replaced at the same time.
	Thrust collar?	Check the flatness of the thrust collar by rotating it on the spider. If it varies by more than 0.02" (0.5 mm) replace the thrust collar.
	Thrust collar bushing?	Check the thrust collar by rocking it on the spider. If it can tilt more than 1/16" (1.6 mm) [as measured at the thrust collar O.D.], replace the bushing in the thrust collar.
	Thrust bearing worn?	Check the thrust bearing to see that it is spinning free. Replace if necessary.
	Blade pitch?	Check blades for consistent pitch. Adjust per Maintenance Section instructions if necessary.
Machine has a perceptible rolling motion while running.	Spider Finger Screws?	Adjust per procedure in Maintenance Section.
	Yoke?	Check to make sure that both fingers of the yoke press evenly on the wear cap. Replace yoke as necessary.

STX-SERIES — TROUBLESHOOTING

TABLE 5. TROUBLESHOOTING (CONTINUED)

SYMPTOM	POSSIBLE PROBLEM	SOLUTION
Lights (optional) not working.	Wiring?	Check all electrical connections, including the master on/off switch and check to see if wiring is in good condition with no shorts. Replace as necessary.
	Lights?	Check to see if light bulbs are still good. Replace if broken.
Retardant spray (optional) not working.	Retardant?	Check the tank to make sure retardant is present. Fill tank as necessary.
	Wiring?	Check all electrical connections, including master on/off switch connections. Replace components and wiring as necessary.
	Bad switch?	Check the continuity of master on/off switch. Replace if broken.
	Bad spray pump?	If pump has a voltage present when the switch is turned on, but does not operate and electrical connections to the pump are good, replace the pump.
Steering is unresponsive.	Blade speed out of adjustment?	See section on blade speed adjustment.
	Worn components?	Check for wear of steering bearings and linkage components replace if necessary.
	Pivots?	Check to ensure free movement of hydraulic drive motors.
	Hydraulic pressure?	Check to ensure that hydraulic steering pressure is adequate. See section on checking hydraulic steering pressure.
Operating position is uncomfortable.	Seat adjust for operator?	Adjust seat with lever located on the front of the seat.
Pitch System not working.	Wiring?	Check and repair wiring and connectors as necessary.
	Spool stuck in solenoid valve?	Replace solenoid valve.

OPERATION MANUAL

HERE'S HOW TO GET HELP

*PLEASE HAVE THE MODEL AND SERIAL
NUMBER ON-HAND WHEN CALLING*

PARTS DEPARTMENT

800-427-1244 or 310-537-3700

FAX: 800-672-7877 or 310-637-3284

SERVICE DEPARTMENT

800-421-1244

FAX: 310-537-4259

TECHNICAL ASSISTANCE

800-478-1244

FAX: 310-631-5032

WARRANTY DEPARTMENT

888-661-4279, or 310-661-4279

FAX: 310-537-1173



MULTIQIP INC.

POST OFFICE BOX 6254

CARSON, CA 90749

310-537-3700 • 800-421-1244

FAX: 310-537-3927

E-MAIL: mq@multiquip.com

WWW.multiquip.com

Atlanta • Boise • Newark
Montreal, Canada • Manchester, UK • Rio De Janeiro, BR • Guadalajara, MX