

# OPERATION MANUAL



**WHITEMAN SERIES**  
**WSHE/A SERIES**  
**VIBRATORY TRUSS SCREED**  
**(HONDA GX270UT2QA2 9HP**  
**GX340UT2QAP2 11HP GASOLINE ENGINES)**

Revision #0 (05/22/12)

*The original manual copy is in American English.*

To find the latest revision of this  
publication, visit our website at:  
[www.multiquip.com](http://www.multiquip.com)



**THIS MANUAL MUST ACCOMPANY THE EQUIPMENT AT ALL TIMES.**

**PN: 36870**

# FUEL AND CHEMICAL EXPOSURE WARNINGS

---



## WARNING

Gasoline engine exhaust and some of its constituents, and some dust created by power sanding, sawing, grinding, drilling and other construction activities contain chemicals known to cause cancer, birth defects and other reproductive harm.

Some examples of these chemicals are:

- Lead from lead-based paints
- Crystalline silica from bricks
- Cement and other masonry products
- Arsenic and chromium from chemically treated lumber

Your risk from these exposures varies, depending on how often you do this type of work. To reduce your exposure to these chemicals: **ALWAYS** work in a well-ventilated area, and work with approved safety equipment, such as dust masks that are specially designed to filter out microscopic particles.

# SILICOSIS/RESPIRATORY WARNINGS

**⚠ WARNING**



**SILICOSIS WARNING**

Grinding/cutting/drilling of masonry, concrete, metal and other materials with silica in their composition may give off dust or mists containing crystalline silica. Silica is a basic component of sand, quartz, brick clay, granite and numerous other minerals and rocks. Repeated and/or substantial inhalation of airborne crystalline silica can cause serious or fatal respiratory diseases, including silicosis. In addition, California and some other authorities have listed respirable crystalline silica as a substance known to cause cancer. When cutting such materials, always follow the respiratory precautions mentioned above.

**⚠ WARNING**

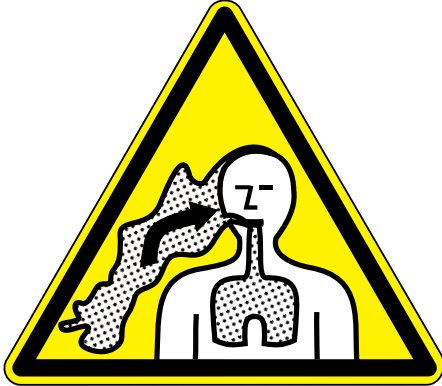

**RESPIRATORY HAZARDS**

Grinding/cutting/drilling of masonry, concrete, metal and other materials can generate dust, mists and fumes containing chemicals known to cause serious or fatal injury or illness, such as respiratory disease, cancer, birth defects or other reproductive harm. If you are unfamiliar with the risks associated with the particular process and/or material being cut or the composition of the tool being used, review the material safety data sheet and/or consult your employer, the material manufacturer/supplier, governmental agencies such as OSHA and NIOSH and other sources on hazardous materials. California and some other authorities, for instance, have published lists of substances known to cause cancer, reproductive toxicity, or other harmful effects.

Control dust, mist and fumes at the source where possible. In this regard use good work practices and follow the recommendations of the manufacturers or suppliers, OSHA/NIOSH, and occupational and trade associations. Water should be used for dust suppression when wet cutting is feasible. When the hazards from inhalation of dust, mists and fumes cannot be eliminated, the operator and any bystanders should always wear a respirator approved by NIOSH/MSHA for the materials being used.

## **WSHE/A Vibratory Truss Screed**

Fuel And Chemical Exposure Warnings .....	2
Silicosis/Respiratory Warnings .....	3
Table Of Contents .....	4
Training Checklist .....	6
Daily Pre-Operation Checklist .....	7
Safety Information .....	8-12
Specifications .....	13-15
Lifting Procedure .....	16
Transporting Procedure .....	17
General Information .....	18-20
Components .....	21-22
Accessories .....	23
Engine Components .....	24
Inspection .....	25-26
Assembly .....	27-33
Operation .....	34-35
Maintenance .....	36-40
Troubleshooting .....	41-42

### **NOTICE**

Specifications are subject to change without notice.



# TRAINING CHECKLIST

Training Checklist			
No,	Description	OK?	Date
1	Read operation manual completely.		
2	Machine layout, location of components, checking of engine oil levels.		
3	Fuel system, refueling procedure.		
4	Operation of controls (machine not running).		
5	Emergency stop procedures.		
6	Startup of machine, engine choke		
7	Alignment of blades		
8	Concrete finishing techniques.		
9	Shutdown of machine.		
10	Lifting of machine .		
11	Assembly of truss sections		
12	Winch operation.		
13	Cleanup procedures.		
16	Machine transport and storage.		

## DAILY PRE-OPERATION CHECKLIST

Daily Pre-Operation Checklist		✓	✓	✓	✓	✓	✓
1	Engine oil level						
2	Bearing lubrication						
3	Condition of blades						
4	Blade alignment						
5	Drive shaft alignment						

# SAFETY INFORMATION

Do not operate or service the equipment before reading the entire manual. Safety precautions should be followed at all times when operating this equipment. Failure to read and understand the safety messages and operating instructions could result in injury to yourself and others.



## SAFETY MESSAGES

The four safety messages shown below will inform you about potential hazards that could injure you or others. The safety messages specifically address the level of exposure to the operator and are preceded by one of four words: **DANGER**, **WARNING**, **CAUTION** or **NOTICE**.

## SAFETY SYMBOLS

**!** **DANGER**

Indicates a hazardous situation which, if not avoided, **WILL** result in **DEATH** or **SERIOUS INJURY**.

**!** **WARNING**

Indicates a hazardous situation which, if not avoided, **COULD** result in **DEATH** or **SERIOUS INJURY**.

**!** **CAUTION**

Indicates a hazardous situation which, if not avoided, **COULD** result in **MINOR** or **MODERATE INJURY**.

**NOTICE**

Addresses practices not related to personal injury.

Potential hazards associated with the operation of this equipment will be referenced with hazard symbols which may appear throughout this manual in conjunction with safety messages.

Symbol	Safety Hazard
	Lethal exhaust gas hazards
	Explosive fuel hazards
	Burn hazards
	Rotating parts hazards
	Pressurized fluid hazards
	Hydraulic fluid hazards



# SAFETY INFORMATION

## GENERAL SAFETY

### CAUTION

- **NEVER** operate this equipment without proper protective clothing, shatterproof glasses, respiratory protection, hearing protection, steel-toed boots and other protective devices required by the job or city and state regulations.



- Avoid wearing jewelry or loose fitting clothes that may snag on the controls or moving parts as this can cause serious injury.
- **NEVER** operate this equipment when not feeling well due to fatigue, illness or when under medication.
- **NEVER** operate this equipment under the influence of drugs or alcohol.



- **ALWAYS** clear the work area of any debris, tools, etc. that would constitute a hazard while the equipment is in operation.
- No one other than the operator is to be in the working area when the equipment is in operation.
- **DO NOT** use the equipment for any purpose other than its intended purposes or applications.

### NOTICE

- This equipment should only be operated by trained and qualified personnel 18 years of age and older.
- Whenever necessary, replace nameplate, operation and safety decals when they become difficult read.
- Manufacturer does not assume responsibility for any accident due to equipment modifications. Unauthorized equipment modification will void all warranties.
- **NEVER** use accessories or attachments that are not recommended by Multiquip for this equipment. Damage to the equipment and/or injury to user may result.
- **ALWAYS** know the location of the nearest fire extinguisher.
- **ALWAYS** know the location of the nearest first aid kit.
- **ALWAYS** know the location of the nearest phone or **keep a phone on the job site**. Also, know the phone numbers of the nearest **ambulance, doctor and fire department**. This information will be invaluable in the case of an emergency.



# SAFETY INFORMATION

## SCREED SAFETY

### DANGER

- Engine fuel exhaust gases contain poisonous carbon monoxide. This gas is colorless and odorless, and can cause death if inhaled.
- The engine of this equipment requires an adequate free flow of cooling air. **NEVER** operate this equipment in any enclosed or narrow area where free flow of the air is restricted. If the air flow is restricted it will cause injury to people and property and serious damage to the equipment or engine.

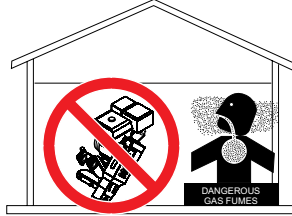

- **NEVER** operate the equipment in an explosive atmosphere or near combustible materials. An explosion or fire could result causing severe **bodily harm or even death.**



### WARNING

- If applicable, **NEVER** use your hand to find hydraulic leaks. Use a piece of wood or cardboard. Hydraulic fluid injected into the skin must be treated by a knowledgeable physician immediately or severe injury or death can occur.



- **ALWAYS** keep clear of rotating or moving parts while operating the screed.



- **NEVER** disconnect any **emergency or safety devices.** These devices are intended for operator safety. Disconnection of these devices can cause severe injury, bodily harm or even death. Disconnection of any of these devices will void all warranties.

### CAUTION

- **NEVER** allow passengers or riders on the screed during operation.
- **NEVER** lubricate components or attempt service on a running machine.

## NOTICE

- **ALWAYS** keep the machine in proper running condition.
- Fix damage to machine and replace any broken parts immediately.
- **ALWAYS** store equipment properly when it is not being used. Equipment should be stored in a clean, dry location out of the reach of children and unauthorized personnel.

## ENGINE SAFETY

### WARNING

- **DO NOT** place hands or fingers inside engine compartment when engine is running.
- **NEVER** operate the engine with heat shields or guards removed.
- Keep fingers, hands hair and clothing away from all moving parts to prevent injury.
- **DO NOT** remove the engine oil drain plug while the engine is hot. The possibility of hot oil exists which could cause severe scalding.



### CAUTION

- **NEVER** touch the hot exhaust manifold, muffler or cylinder. Allow these parts to cool before servicing equipment.



## NOTICE

- **NEVER** run engine without an air filter or with a dirty air filter. Severe engine damage may occur. Service air filter frequently to prevent engine malfunction.
- **NEVER** tamper with the factory settings of the engine or engine governor. Damage to the engine or equipment can result if operating in speed ranges above the maximum allowable.



# SAFETY INFORMATION

## FUEL SAFETY

### DANGER

- **DO NOT** start the engine near spilled fuel or combustible fluids. Fuel is extremely flammable and its vapors can cause an explosion if ignited.
- **ALWAYS** refuel in a well-ventilated area, away from sparks and open flames.
- **ALWAYS** use extreme caution when working with **flammable** liquids.
- **DO NOT** fill the fuel tank while the engine is running or hot.
- **DO NOT** overfill tank, since spilled fuel could ignite if it comes into contact with hot engine parts or sparks from the ignition system.
- Store fuel in appropriate containers, in well-ventilated areas and away from sparks and flames.
- **NEVER** use fuel as a cleaning agent.
- **DO NOT** smoke around or near the equipment. Fire or explosion could result from fuel vapors or if fuel is spilled on a hot engine. 

## TRANSPORTING SAFETY

### CAUTION

- **NEVER** allow any person or animal to stand underneath the equipment while lifting. 
- **NEVER** lift or transport screed with personnel standing on the screed.
- Use proper heavy lifting procedures when lifting the screed.

### NOTICE

- Machine can be transported on flatbed truck of proper weight capacity.
- The easiest way to lift the screed is to attach lifting hooks to the screed frame. Lifting hooks should be placed at equal distances from each end of the screed.

A strap or chain can be attached to these hooks, allowing a forklift or crane to lift the screed up onto and off of a slab of concrete. The strap or chain should have a minimum of 2,000 pounds (1,000 kg) lifting capacity and the lifting device must be capable of lifting at least this amount.

- Always make sure crane or lifting device has been properly secured to the lifting hooks on the equipment.
- **ALWAYS** shutdown engine before transporting.
- **NEVER** lift the equipment while the engine is running.
- Tighten fuel tank cap securely and close fuel cock to prevent fuel from spilling.
- Use adequate lifting cable (wire or rope) of sufficient strength.
- **DO NOT** lift machine to unnecessary heights.
- **ALWAYS** tie down equipment during transport by securing the equipment with rope.

## TOWING SAFETY

### CAUTION

- Check with your local county or state safety towing regulations, in addition to meeting **Department of Transportation (DOT) Safety Towing Regulations**, before towing your screed. 
- In order to reduce the possibility of an accident while transporting the screed on public roads, **ALWAYS** make sure the trailer that supports the screed and the towing vehicle are mechanically sound and in good operating condition.
- **ALWAYS** shutdown engine before transporting
- Make sure the hitch and coupling of the towing vehicle are rated equal to, or greater than the trailer “gross vehicle weight rating.”
- **ALWAYS** inspect the hitch and coupling for wear. **NEVER** tow a trailer with defective hitches, couplings, chains, etc.
- Check the tire air pressure on both towing vehicle and trailer. **Trailer tires should be inflated to 50 psi cold.** Also check the tire tread wear on both vehicles.

## SAFETY INFORMATION

- **ALWAYS** make sure the trailer is equipped with a **safety chain**.
- **ALWAYS** properly attach trailer's safety chains to towing vehicle.
- **ALWAYS** make sure the vehicle and trailer directional, backup, brake and trailer lights are connected and working properly.
- DOT Requirements include the following:
  - Connect and test electric brake operation.
  - Secure portable power cables in cable tray with tie wraps.
- The maximum speed for highway towing is 55 MPH unless posted otherwise. Recommended off-road towing is not to exceed 15 MPH or less depending on type of terrain.
- Avoid sudden stops and starts. This can cause skidding, or jack-knifing. Smooth, gradual starts and stops will improve towing.
- Avoid sharp turns to prevent rolling.
- Trailer should be adjusted to a level position at all times when towing.
- Raise and lock trailer wheel stand in up position when towing.
- Place **chock blocks** underneath wheel to prevent rolling while parked.
- Place support blocks underneath the trailer's bumper to prevent tipping while parked.
- Use the trailer's swivel jack to adjust the trailer height to a level position while parked.

### ENVIRONMENTAL SAFETY/DECOMMISSIONING

#### NOTICE

Decommissioning is a controlled process used to safely retire a piece of equipment that is no longer serviceable. If the equipment poses an unacceptable and unrepairable safety risk due to wear or damage or is no longer cost effective to maintain (beyond life-cycle reliability) and is to be decommissioned (demolition and dismantlement), be sure to follow rules below.

- **DO NOT** pour waste or oil directly onto the ground, down a drain or into any water source.
- Contact your country's Department of Public Works or recycling agency in your area and arrange for proper disposal of any electrical components, waste or oil associated with this equipment.
- When the life cycle of this equipment is over, it is recommended that the screed frame and all other metal parts be sent to a recycling center.



Metal recycling involves the collection of metal from discarded products and its transformation into raw materials to use in manufacturing a new product.

Recyclers and manufacturers alike promote the process of recycling metal. Using a metal recycling center promotes energy cost savings.

#### NOTICE

The gasoline engine used in this equipment has been designed to reduce harmful levels of carbon monoxide (CO), hydrocarbons (HC) and nitrogen oxides (NOx) contained in diesel exhaust emissions.

This engine has been certified to meet US EPA Evaporative emissions requirements in the installed configuration.

Attempting to modify or make adjustments to the engine emission system by unauthorized personnel without proper training could damage the equipment or create an unsafe condition.

Additionally, modifying the fuel system may adversely affect evaporative emissions, resulting in fines or other penalties.

#### Emission Control Label

The emission control label is an integral part of the emission system and is strictly controlled by regulations.

The label must remain with the engine for its entire life.

If a replacement emission label is needed, please contact your authorized Honda Engine Distributor.

# SPECIFICATIONS

<b>Table 1. Engine-Powered Screeds</b>		
Recommended Slump	3 in (76 mm)	
Max. Concrete Depth	8 in (203 mm)	
Max Screed Width	65 ft (19.8 m)	
<b>Model</b>	<b>Description</b>	<b>Weight lb. (kg)</b>
WSHE20	2 foot (.61 m) truss with eccentric shaft vibration	46 (20)
WSHE25	2.5 foot (.76 m) truss with eccentric shaft vibration	50 (23)
WSHE50	5 foot (1.5 m) truss with eccentric shaft vibration	95 (43)
WSHE75	7.5 foot (2.3 m) truss with eccentric shaft vibration	136 (62)
WSHE100	10 foot (3.1 m) truss with eccentric shaft vibration	190 (86)
<b>Accessories</b>		
<b>Model</b>	<b>Description</b>	<b>Weight lb. (kg)</b>
WSHEH	End handles (two each)	54 (27)
WSHW	Manual Winches, set of two	42 (19)
WSHSPW(L)	Self-propelled winch (left side), includes 2.5 foot truss	105 (48)
WSHSPW(R)	Self-propelled winch (right side), includes 2.5 foot truss	105 (48)
WSHRBE	Reinforcement bracket, engine screed	6 (2.7)
WSKITAEB	Adjustable end brackets, set of two, skid type	24 (11)
WSKITAEBR	Adjustable end brackets, set of two, roller type	26 (12)
WSHEKITUJ	Invert/crown kit, for adjustments up to ¼-inch per foot	22 (10)
WSHEIC	Invert/crown kit, for adjustments in excess of ¼-inch per foot	98 (41)
WSHEKIT9H	9 HP Engine Kit	112 (51)
WSHE50KIT9H	9 HP Engine Kit installed on 5 foot truss section	207 (94)
WSHEKIT11H	11 HP Engine Kit	112 (51)
WSHE50KIT11H	11 HP Engine Kit installed on 5 foot truss section	207 (94)
36243	Truss screed dolly	50 (23)

# SPECIFICATIONS

<b>Table 2. Air-Powered Screeds</b>		
Recommended Slump	2 in + (51 mm +)	
Max. Concrete Depth	12 in (305 mm)	
Max Screed Width	65 ft (19.8 m)	
<b>Model</b>	<b>Description</b>	<b>Weight lb. (kg)</b>
WSHA20	2 foot (.61 m) truss	45 (20)
WSHA25	2.5 foot (.76 m) truss with 2 air piston vibrators	50 (23)
WSHA50	5 foot (1.5 m) truss with 4 air piston vibrators	95 (43)
WSHA75	7.5 foot (2.3 m) truss with 6 air piston vibrators	136 (62)
WSHA100	10 foot (3.1 m) truss with 8 air piston vibrators	190 (86)
<b>Accessories</b>		
<b>Model</b>	<b>Description</b>	<b>Weight lb. (kg)</b>
WSHAH	End handles (two each) and air regulator kit	54 (27)
WSHW	Manual Winches, set of two	42 (19)
WSHRBA	Reinforcement bracket, air screed	6 (2.7)
WSKITAEB	Adjustable end brackets, set of two, skid type	24 (11)
WSKITAEBR	Adjustable end brackets, set of two, roller type	26 (12)
WSHAIC	Invert/crown kit, for adjustments in excess of ¼-inch per foot	62 (28)
36243	Truss screed dolly	50 (23)

<b>Table 3. Noise and Vibration Emissions for WSHEKIT9H</b>	
Guaranteed ISO 11201:2010 Based Sound Pressure Level at Operator Station in dB(A)	88
Guaranteed ISO 3744:2010 Based Sound Power Level in dB(A)	105

**NOTES:**

1. *Sound Pressure and Power Levels are "A" weighted Measures per ISO 226:2003 (ANSI S1.4-1981). They are measured with the operating condition of the machine which generates the most repeatable but highest values of the sound levels. Under normal circumstances, the sound level will vary depending on the condition of the material being worked upon.*

# SPECIFICATIONS

**Table 4. Engine Specifications/Dimensions**

<b>Model</b>	<b>Honda GX270UT2QA2 Engine</b>	<b>Honda GX340UT2QAP2 Engine</b>
Type	Air-cooled 4 stroke, Single Cylinder, OHV, Horizontal Shaft Gasoline Engine	Air-cooled 4 stroke, Single Cylinder, OHV, Horizontal Shaft Gasoline Engine
Bore X Stroke	3.0 in. X 2.3 in. (77 mm x 58 mm)	3.4 in. X 2.5 in. (88 mm x 64 mm)
Displacement	16.4 cu-in. (270 cc)	23.7 cu-in. (389 cc)
Max. Output	9.0 H.P. @ 3600 RPM	11.0 H.P. @ 3600 RPM
Fuel Tank Capacity	Approx. 1.95 U.S. Gallons (6.0 Liters)	Approx. 1.95 U.S. Gallons (6.0 Liters)
Fuel	Unleaded Gasoline	Unleaded Gasoline
Lube Oil Capacity	1.06 qt. (1.1 liters)	1.06 qt. (1.1 liters)
Oil Type	4-Stroke API, SF or SG SAE 10W-30 General Use	4-Stroke API, SF or SG SAE 10W-30 General Use
Speed Control Method	Centrifugal Fly-weight Type	Centrifugal Fly-weight Type
Cooling System	Forced Air	Forced Air
Starting Method	Recoil Start	Recoil Start
Spark Plug Type	BPR6ES NGK	BPR6ES NGK
Spark Plug Gap	0.028-0.031 in. (0.70 - 0.80 mm)	0.028-0.031 in. (0.70 - 0.80 mm)
Dimension (L x W x H)	15.0 x 16.8 X 16.6 in. (381 X 428 X 422 mm)	15.9 x 18.1 X 17.6 in. (406 X 460 X 448 mm)
Dry Net Weight	55.1 lbs (25 Kg.)	69.8 lbs (31.7 Kg.)

# LIFTING PROCEDURE

## LIFTING THE SCREED

The following procedure and Figure 1 describe how to lift the vibratory screed.

### **WARNING**

**NEVER** lift the screed to unnecessary heights. **ALWAYS** make sure that no one is standing underneath the screed while it is being lifted.

1. Attach the U-shaped hanger and associated hardware to the top of each truss frame section as shown in Figure 1. Tighten hanger securely so that it will not slip.

2. Utilize a spreader bar of proper length and lifting capacity. Secure lifting straps from both ends of the spreader bar to the attached lifting hangers.
3. Connect lifting cables from the spreader bar to the lifting hook of a crane or forklift. Ensure that the lifting hook and chain are of appropriate lifting capacity.
4. Use crane or forklift to hoist screed onto a flatbed truck for transporting or onto the form for screeding.

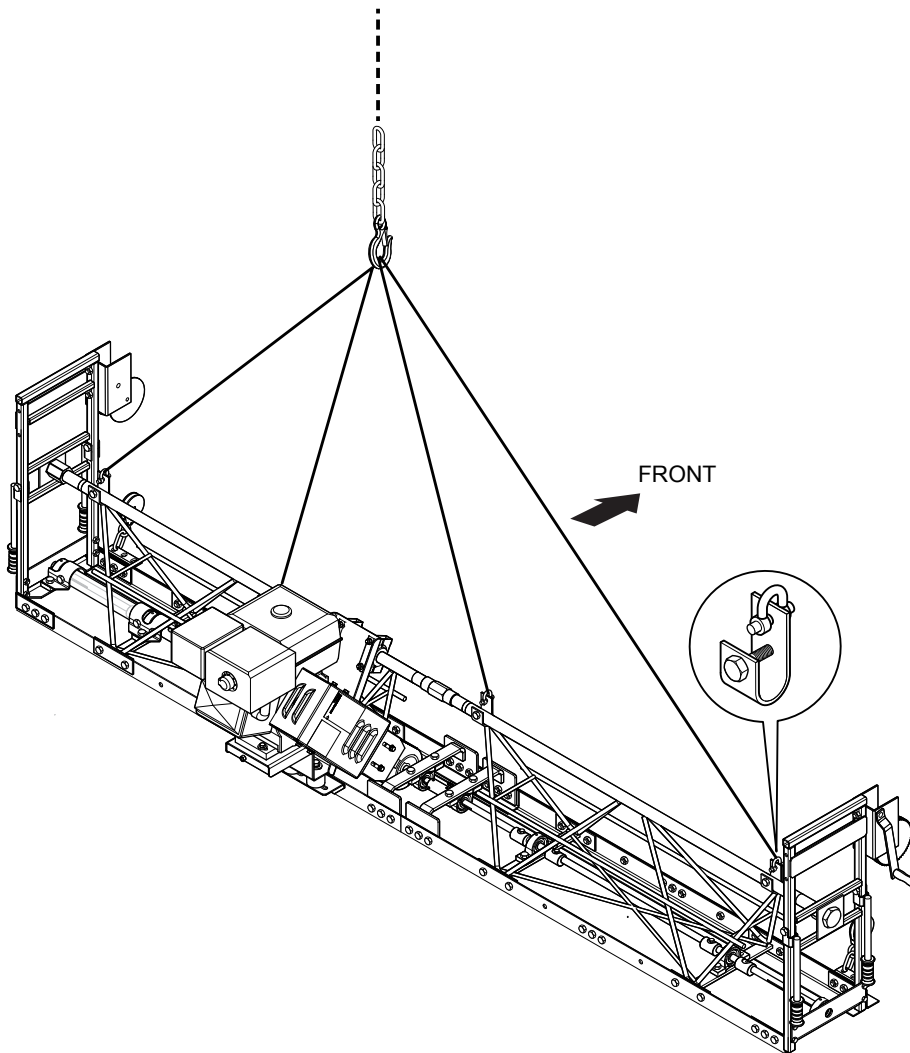

Figure 1. Lifting the Screed



# TRANSPORTING PROCEDURE

---

## TRANSPORTING THE SCREED

Place the screed on a flatbed truck during transportation as shown in Figure 2. Attach suitable tie-down straps to the screed to secure it to the truck. Route tie-down straps over truss frame sections as required.

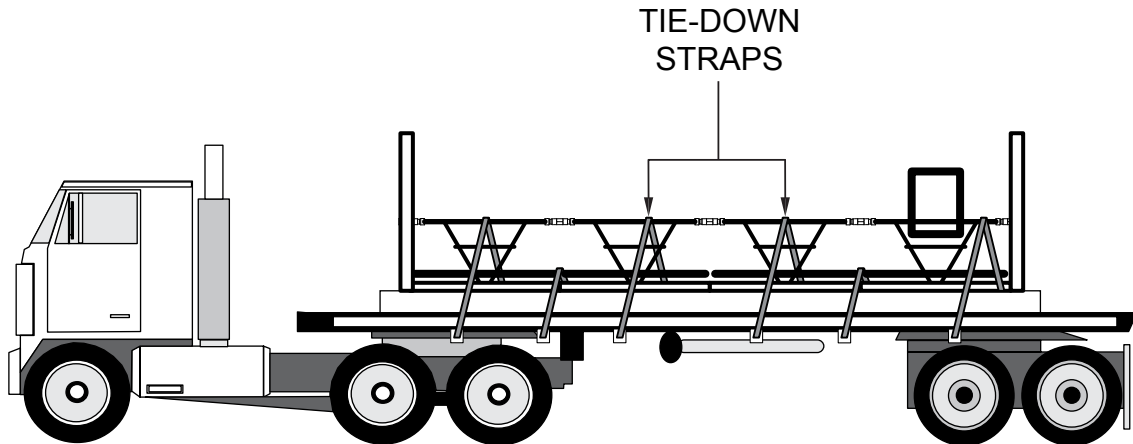

TYPICAL TIE-DOWN APPLICATION

**Figure 2. Screed Tie-Down Points**

# GENERAL INFORMATION

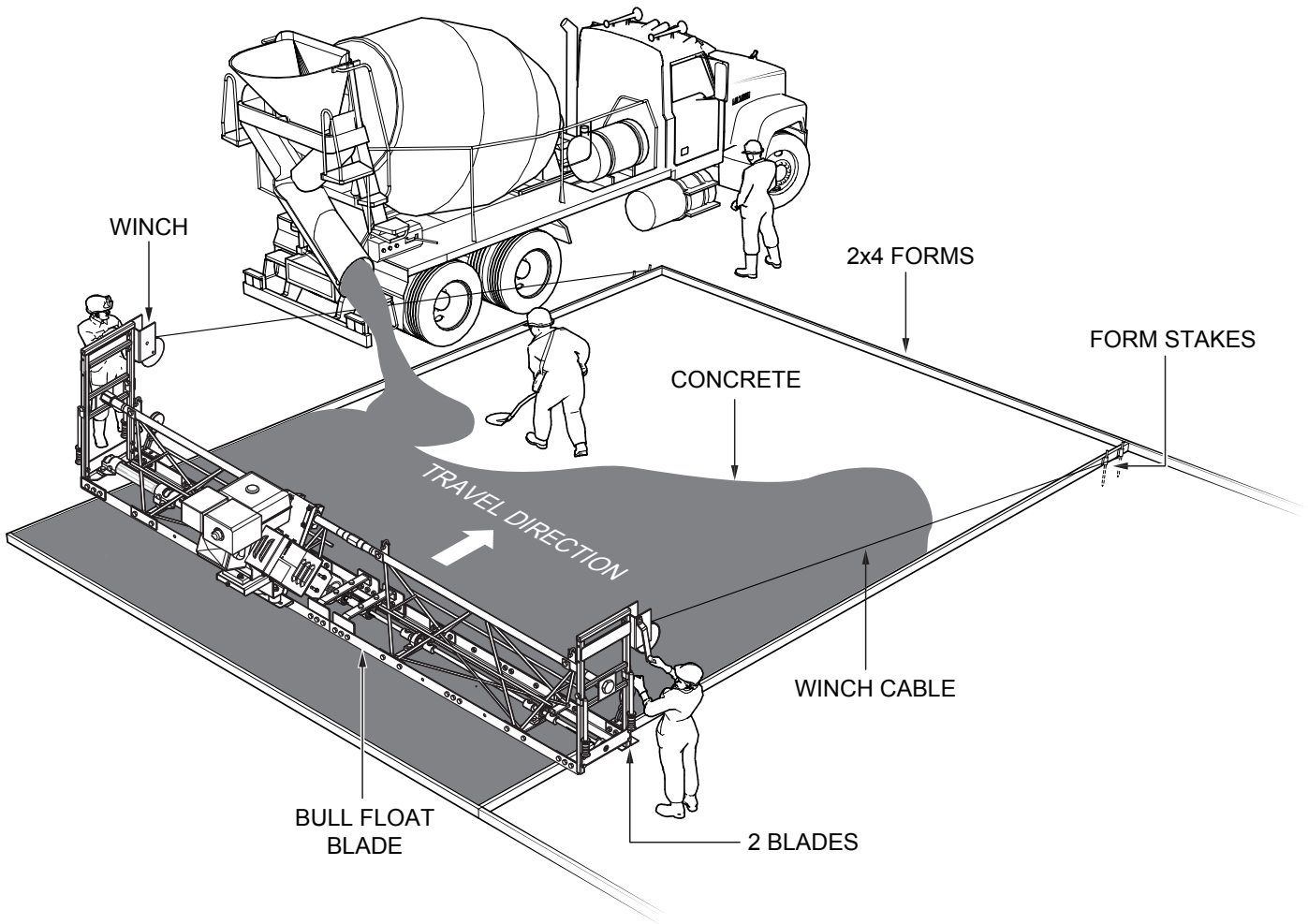

Figure 3. Vibratory Screed Application

## GENERAL INFORMATION

Multiquip vibratory truss screeds are used for leveling pavement and industrial floors. They are available in air-powered and engine-driven configurations. The vibratory truss screeds provide dependable performance on job after job. Its modular design allows the ability to configure the screed by adding or removing sections as needed. Figure 3 represents a typical vibratory screed application.

### HEAVY-DUTY STEEL CONSTRUCTION

The Multiquip vibratory truss screed uses a triangular frame design (Figure 4), built to take the abuse of rough handling on a jobsite. Unlike the lightweight aluminum screed, the steel screed will hold its precise shape better on long pours and over a longer period of time. Additionally, the heavier steel screed will stay down on the forms and will not ride up during a pour. This vibratory screed weighs approximately 14 pounds per foot.

### STEEL TRUSS DESIGN

The steel construction keeps the screed from riding up on stiff concrete mix designs.

The vibratory truss screed features top pipe manufactured from schedule 80 steel and features 16 TPI thread to provide fine grade control should crowns or inverts be required.

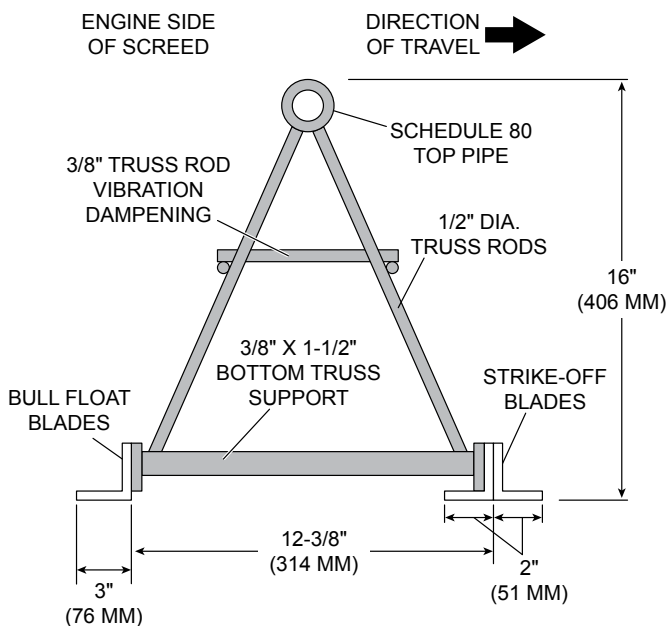

Figure 4. Screed Cross Section

### FOUR DIFFERENT LENGTHS

Multiquip Vibratory Screeds come in four lengths: 2-1/2 ft., 5 ft., 7-1/2 ft. and 10 ft. sections.

#### NOTICE

It is best to allow a minimum overhang past the forms (6" to 12" is ideal).

### STANDARDIZATION (AIR AND ENGINE DRIVEN)

Multiquip uses the same frame for both the air and engine driven screeds. The top pipe is drilled and tapped to allow air connections for the air vibrators.

### SCREED BLADES

The screed blades are constructed of 10-gauge galvanized steel for rust resistance and maximum durability. The front blades consist of two 1-1/2" high x 2" wide angles. This gives the screed blades 2-1/2 inches of concrete surcharge and 4 inches of screed surface. The rear (bull float) blade is a single blade 2-1/2" wide. A total of 7 inches of concrete surface contact is provided by the screed.

### BOLT-ON BLADE DESIGN

The WSHE/A vibratory truss screeds features a bolt-on blade design to allow easy replacement of worn or damaged blades.

### AIR-POWERED SCREED

Air vibrators offer high frequency (up to 9500 vibrations per minute at 60 PSI) for excellent consolidation of low slump mixes. The screed is capable of striking off slabs up to 11 inches thick (performance may vary according to mix design and job requirements).

The vibrators are placed on 30-inch centers and located at both front and rear blades for uniform vibration. Air consumption is approximately 4CFM for each vibrator at 60 PSI. Crowns/Inverts up to 1/4" per foot are attainable without an optional kit.

### ENGINE DRIVEN SCREED

The engine-driven screed has an eccentric shaft design that produces 8,000 vibration cycle nodes per minute. It is ideal for slab, bridge, and highway applications. The engine-driven screed is powered by either a 9 HP or 11 HP Honda engine. Engine kits are available factory installed on 5-foot truss sections for reduced setup time at the job site. Winch options include manual or self-propelled models.

# GENERAL INFORMATION

---

Self-propelled models are each mounted on a 2.5-foot section of the screed. Crowns/Inverts may be obtained with optional kits.

## ROTATING ECCENTRIC SHAFT (RES) VIBRATORY SCREED

The rotating eccentric shaft produces over 8000 VPM. The shaft is built of 3/4" diameter, high strength steel with 1-3/8" diameter dual eccentrics bolted on 30" centers. The shaft is supported by heavy-duty, solid-mounted pillow block bearings (the bearings are greaseable and provide long life and solid transmission of vibration through the lower frame and blades into the concrete).

## PROPELLING THE SCREED

Several options are available for moving the screed during a pour.

1. **Manual Winches** — Heavy Duty 2500 lb., 2 speed winches with 100 feet of 1/8" aircraft cable can be located on either end of the screed or with the addition of a pulley kit, both sides of the screed can be winched from on side.
2. **Hydraulic Winches** — By adding a pulley to the rotating eccentric shaft, power can be harnessed to drive a small Parker hydraulic pump. This pump provides power to an Eaton drive motor driving the winches located on either side of the screed. The speed of the winch is variable from 0 to 12 feet per minute.

## INVERTS AND CROWNS

Multiquip Vibratory Screeds can be aligned to form inverts or crowns with the use of special Invert/Crown Brackets, Flex-Joint or U-Joint kits. Crowns of up to 1/4-inch per foot are considered normal. Most highway specifications call for 1/4-inch per foot or 2% crowns. (.25 inches per 12 inches)

## SCREED WIDTH

The recommended maximum length is 65 feet for both air and engine driven screeds. With lengths over 35 feet, the engine should be mounted on a center section of the screed. This increases efficiency and equalizes the load on the driveshaft.

## SLAB THICKNESS

Like soil compaction, slab thickness is variable. Maximum slab thickness depends on the concrete mix, type of forms used, travel speed and other variables. The Rule of Thumb is: 8 to 9 inches for the RES type and up to 12 inches for the air screed.

## RATE OF TRAVEL

The rate of travel for the screed varies. The men working the concrete should maintain a slight discharge of concrete in front of the screed. (**DO NOT** allow concrete to flow over the screed blades by more than 2-1/2".) As you move the screed forward, you should be getting a nice, creamy surface behind the bull float blade. Increase the travel speed until the surface deteriorates and then slow down slightly to achieve maximum travel speed.

## COMMONLY ASKED QUESTIONS:

1. "How wide can I go with the vibratory screed?"

Recommended maximum length is 65 feet for both air and engine driven screeds. With lengths over 20 feet, the engine should be mounted on a center section of the screed. This increases efficiency and equalizes the load on the driveshaft.

2. "What is the maximum slab thickness I can expect to effectively consolidate?"

Like soil compaction, this is variable. It depends on the concrete mix, type of forms used, travel speed and other variables. The rule of thumb is: 8 to 9 inches for the RES type and up to 12 inches for the air screed.

3. "At what rate of travel should I work the screed?"

It varies. The men working the concrete should maintain a slight discharge of concrete in front of the screed. (Do not allow concrete to flow over the screed blades by more than 2-1/2".) As you move the screed forward, you should be getting a nice, creamy surface behind the bull float blade. Increase the travel speed until the surface deteriorates and then slow down slightly to achieve maximum travel speed.

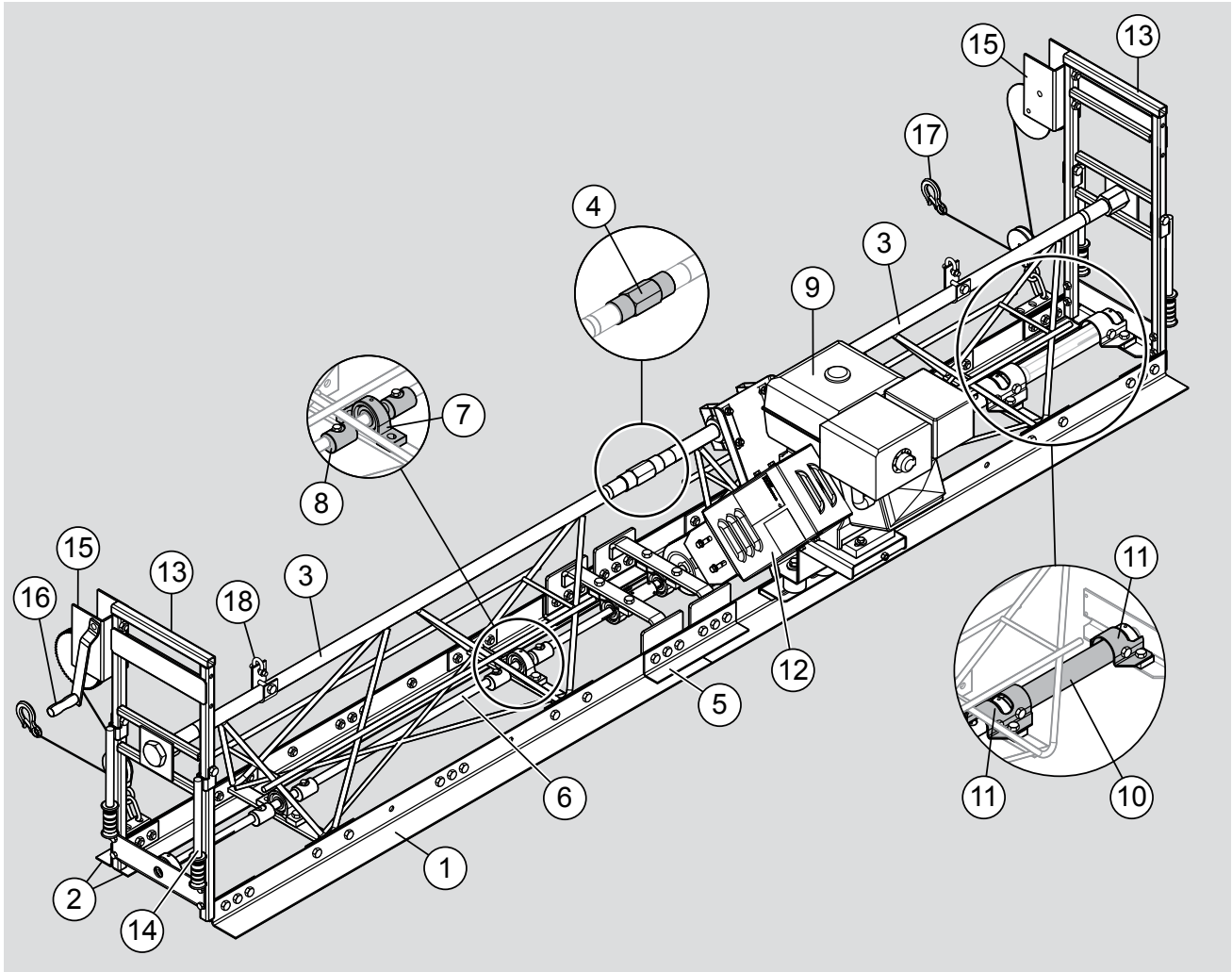

**Figure 5. WSHE Components**

Figure 5 and Figure 6 show the location of the basic components of a 10-foot WSHE/A screed. The function of each component is described below.

1. **Rear (Bull Float) Blade** — 2-1/2" high x 3" wide blade, constructed of 10-gauge galvanized steel.
2. **Front Blades** — two 2-1/2" high x 2" wide blades, constructed of 10-gauge galvanized steel.
3. **Truss Frame** — Available in four lengths: 2-1/2 ft., 5 ft., 7-1/2 ft. and 10 ft. (two 5 ft. sections illustrated above). Each frame section features a heavy-duty schedule 80 top pipe for structural integrity.
4. **Turnbuckle** — Connects two truss sections together. Fine threads allow controlled adjustment for slight crown or invert configurations.
5. **Blade Connector** — Connects two blades together. Bolt-on blade design allows for easy replacement of worn or damaged blades.
6. **Rotating Eccentric Shaft** — Produces over 8000 VPM, built of 3/4" diameter, high strength steel.
7. **Pillow Block Bearings** — Support rotating shaft.
8. **Eccentric Weights** — Bolted onto rotating shaft to produce vibration.
9. **Engine** — Honda GX270 or GX340 engine drives the rotating shaft.
10. **Guard Tube** — Covers the rotating shaft to prevent equipment damage and operator injury.
11. **Tube Mounts** — Secure guard tubes to the truss frame.
12. **Belt Guard** — Covers the rotating V-belt to prevent operator injury.

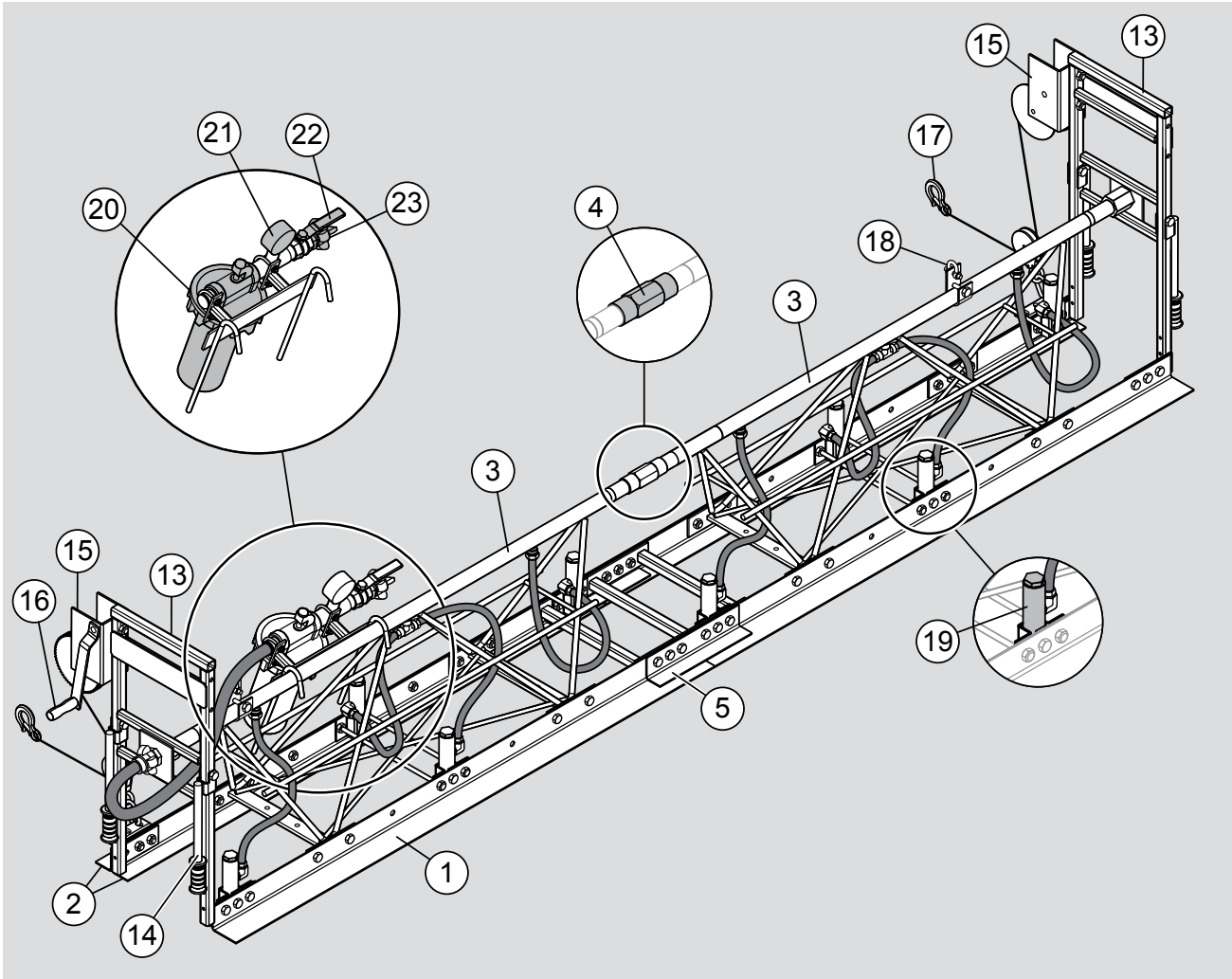

**Figure 6. WSHA Components**

- 13. **End Handle Section** — Two end handle sections required for screed assembly.
- 14. **End Handle** — Allows lifting of screed onto and off of slab.
- 15. **Manual Winch** — Heavy duty 2500 lb, 2 speed winch with 100 feet of 1/8" aircraft cable located on one or both ends of the screed. Self-propelled hydraulic winch option minimizes labor and offers speeds from 0 to 12 feet per minute.
- 16. **Winch Handle** — Rotate handle to facilitate screed movement.
- 17. **Cable Hook** — Fastened to stationary point in line of screed travel.
- 18. **Lifting Hanger** — One hanger located on both ends of the screed.
- 19. **Air Vibrator** — Naval bronze piston vibrators produce 9,500 vibrations per minute.
- 20. **Oil Mist Lubricator** — Holds one quart of oil to lubricate air vibrators. Multiquip recommends SAE 10 wt. non-gumming type oil.
- 21. **Air Gauge** — Indicates vibrator air pressure.
- 22. **On-Off Valve** — Rotate valve to allow air to flow into or prevent air from entering vibrators.
- 23. **Quick-Disconnect Coupler** — Connects screed to air compressor.

**NOTICE**

The air vibrator operates at 80 PSI, consuming only 4.5 CFM of air to provide effective consolidation of concrete without over-vibration.

# ACCESSORIES

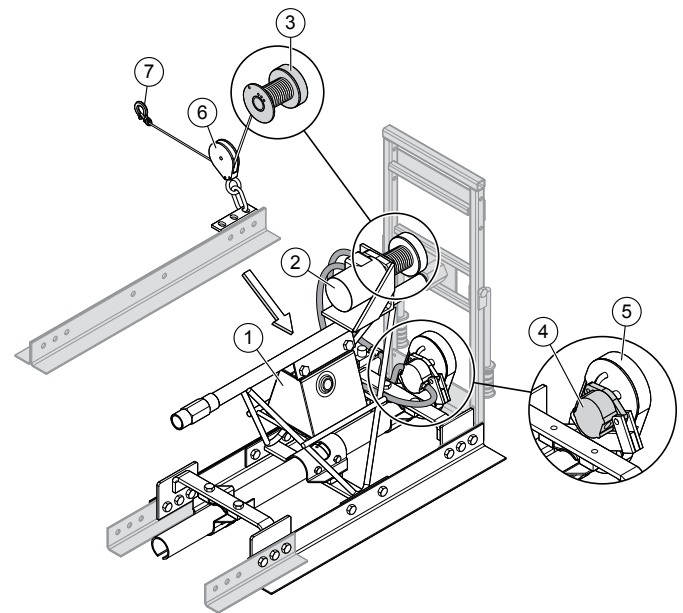
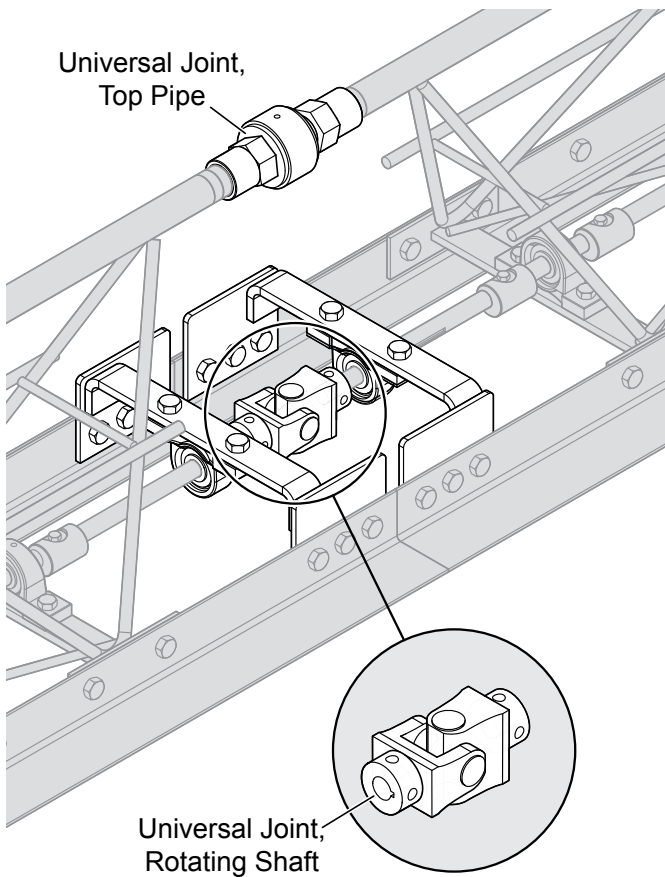
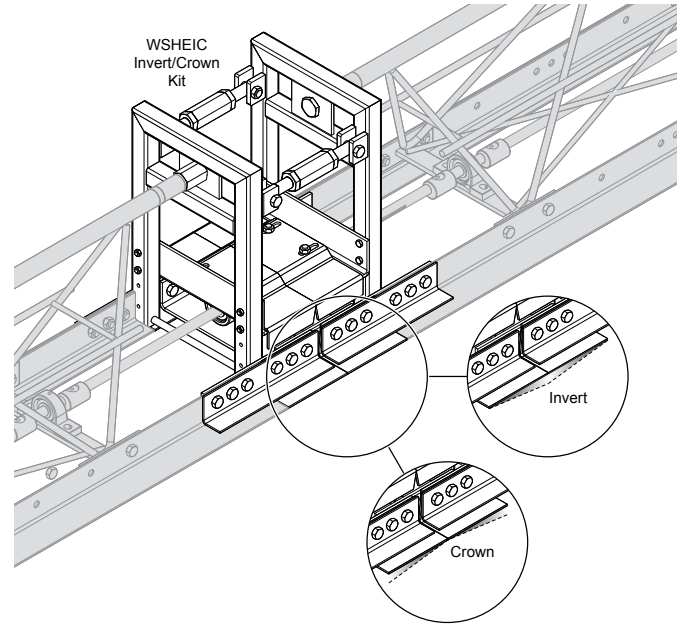
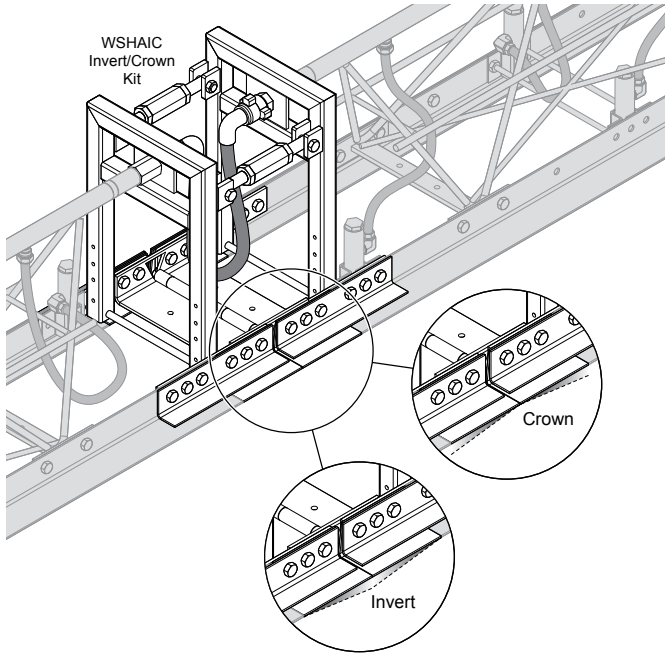
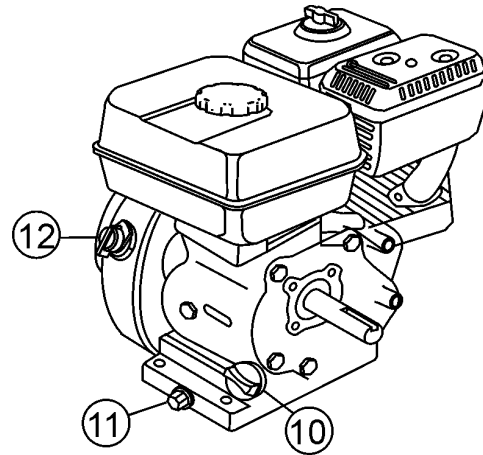
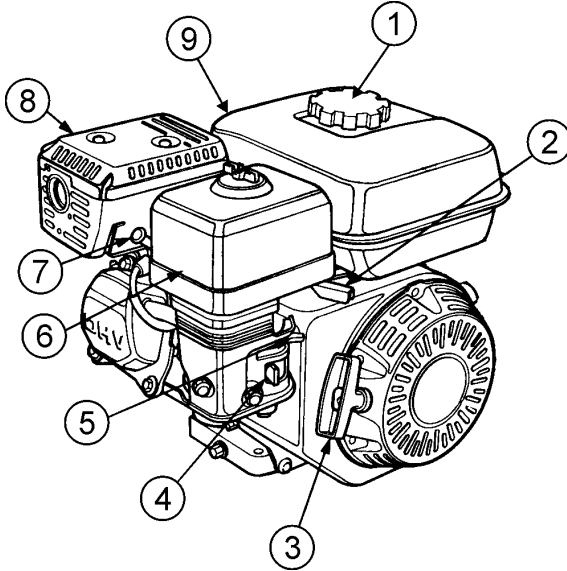

Figure 7. Accessories

# ENGINE COMPONENTS



## INITIAL SERVICING

Figure 8. Engine Controls and Components

The engine (Figure 8) must be checked for proper lubrication and filled with fuel prior to operation. Refer to the manufacturer's engine manual for instructions and details of operation and servicing.

1. **Fuel Filler Cap** – Remove this cap to add unleaded gasoline to the fuel tank. Make sure cap is tightened securely. **DO NOT** over fill.

### DANGER



Add fuel to the tank only when the engine is stopped and has had an opportunity to cool down. In the event of a fuel spill, **DO NOT** attempt to start the engine until the fuel residue has been completely wiped up and the area surrounding the engine is dry.

2. **Throttle Lever** – Used to adjust engine RPM speed. This lever is connect to the throttle lever cable located on the handle bars. Reference throttle cable installation procedure in this manual.
3. **Recoil Starter (pull rope)** – Manual-starting method. Pull the starter grip until resistance is felt, then pull briskly and smoothly.
4. **Fuel Valve Lever** – **OPEN** to let fuel flow, **CLOSE** to stop the flow of fuel.
5. **Choke Lever** – Used in the starting of a cold engine, or in cold weather conditions. The choke enriches the fuel mixture.

6. **Air Cleaner** – Prevents dirt and other debris from entering the fuel system. Remove wing-nut on top of air filter canister to gain access to filter element.

### NOTICE

Operating the engine without an air filter, with a damaged air filter, or a filter in need of replacement will allow dirt to enter the engine, causing rapid engine wear.

7. **Spark Plug** – Provides spark to the ignition system. Set spark plug gap according to engine manufacturer's instructions. Clean spark plug once a week.
8. **Muffler** – Used to reduce noise and emissions. **NEVER** touch when **hot!**
9. **Fuel Tank** – Fill with unleaded gasoline. Reference Table 4 for fuel tank capacity. For additional information refer to Honda engine owner's manual.
10. **Dipstick/Oil Filler Cap** – Remove this cap to determine if the engine oil is low. Add oil through this filler port as recommended in Table 5.
11. **Oil Drain Plug** – Remove this plug to remove oil from the engine's crankcase.
12. **Engine ON/OFF Switch** – **ON** position permits engine starting, **OFF** position stops engine operation.



## Inspection Screenshot

1. Read all safety instructions at the beginning of manual.
2. Clean the entire screed, removing dirt and concrete debris from the truss screed sections.
3. Make sure that the all bolts are secure and will not vibrate loose.
4. Check for loose set screws on all shaft couplers.
5. Check jam nuts on top pipe to ensure that they are tight against the top pipe coupler.
6. Check the oil and fuel levels of the engine (for engine-driven screeds).
7. Check bearings for grease (bearings are pre-greased from the manufacturer).
8. Check winch cables to make sure that they will not become loose during the screed run.
9. Look over the forms to check for unevenness so that the screed will not hang up.

## Inspection Engine

1. Clean the engine, removing dirt and dust, particularly the engine cooling air inlet, carburetor and air cleaner.
2. Check the air filter for dirt and dust. If air filter is dirty, replace air filter with a new one as required.
3. Check carburetor for external dirt and dust. Clean with dry compressed air.
4. Check engine mounting hardware fastening nuts and bolts for tightness.

## Engine Oil Check

1. To check the engine oil level, place the screed on secure level ground with the engine stopped.
2. Remove the dipstick from the engine oil filler hole (Figure 9) and wipe clean.

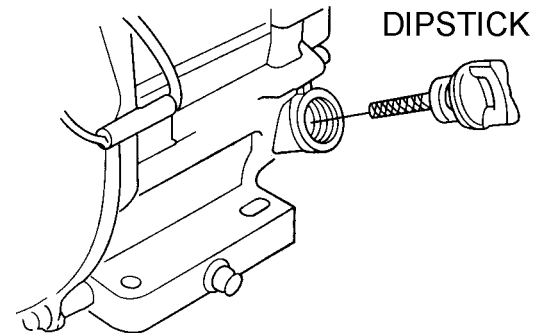

**Figure 9. Engine Oil Dipstick Removal**

3. Insert and remove the dipstick without screwing it into the filler neck. Check the oil level shown on the dipstick.
4. If the oil level is low (Figure 10), fill to the edge of the oil filler hole with the recommended oil type as listed in Table 5. Reference Table 4 for maximum engine oil capacity.

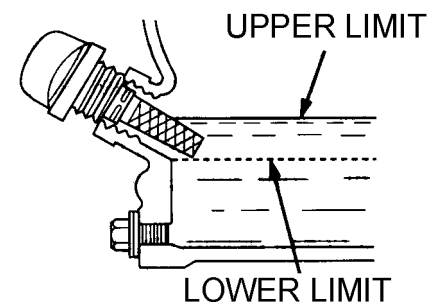

**Figure 10. Engine Oil Dipstick (Oil Level)**

Table 5. Oil Type		
Season	Temperature	Oil Type
Summer	25°C or Higher	SAE 10W-30
Spring/Fall	25°C~10°C	SAE 10W-30/20
Winter	0°C or Lower	SAE 10W-10

**DANGER**



**EXPLOSIVE FUEL!**

Motor fuels are highly flammable and can be dangerous if mishandled. **DO NOT** smoke while refueling. **DO NOT** attempt to refuel the trowel if the engine is hot! or running.

**Fuel Check**

1. Visually inspect to see if fuel level is low. If fuel is low, replenish with unleaded fuel.
2. When refueling, be sure to use a strainer for filtration. **DO NOT** top-off fuel. Wipe up any spilled fuel immediately.

**Pillow Block Bearing Lubrication**

1. Each truss section has a set of pillow block bearings (Figure 11) that will require lubrication. Always make sure that the bearings are lubricated before each use of the screed. See maintenance section in this manual for bearing lubrication intervals..

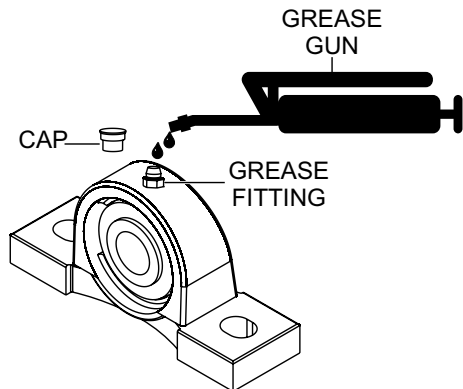

**Figure 11. Bearing Lubrication**

**V-Belt Check**

A worn or damaged V-belt (Figure 12) can adversely affect the performance of the screed (gas driven). If a V-belt is defective or worn simply replace the V-belt as outlined in the maintenance section of this manual.

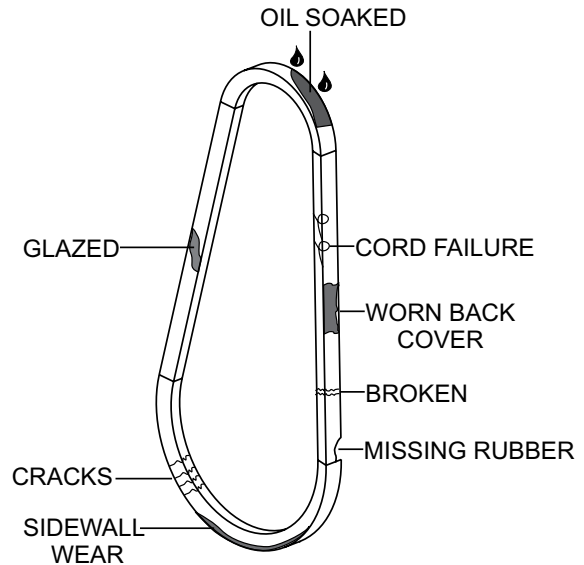

**Figure 12. V-Belt Check**

**V-Belt Guard Check**

Check for damage, loose or missing hardware.

**Blade Check**

Check for worn or damaged blades (Figure 13). Check to see if one blade is worn out while the others look new. Replace any worn blades.

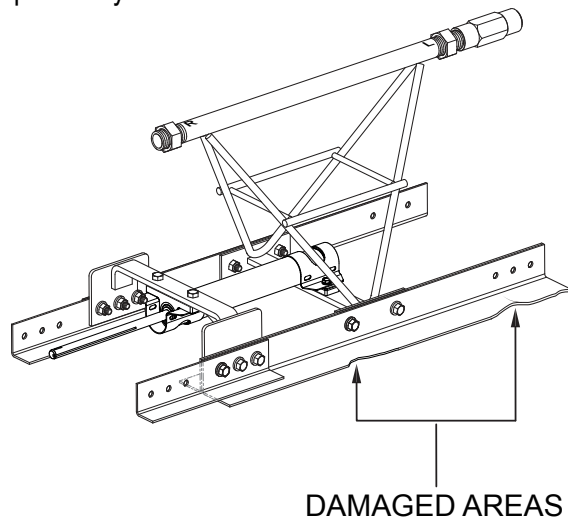

**Figure 13. Blade Inspection**

## ASSEMBLY

**ALWAYS** assembled screed on a flat surface that is free of debris and foreign objects. For best result place screed on a flat platform during assembly. This will ensure flatness of the screed blades when assembly is complete.

Things to remember during and after assembly:

- **ALWAYS** make sure eccentric drive shaft is properly aligned.
- Make sure eccentric weights are installed correctly. Reference Figure 35 for correct orientation.
- If eccentric weights are mismatched screed will not vibrate properly.
- **DO NOT** overspeed, engine speed must not exceed 3600 RPM.
- **NEVER** let concrete build on front blade. This condition causes the screed to be stressed and make turning of the winch handles difficult.
- **DO NOT** over vibrate concrete.
- Turn winch handles simultaneously to keep screed even.

The illustrations referenced in this section describe how to assemble the vibratory screed. Listed below are the various assemblies that will have to be assembled. End Handle Section

### ■ Engine Section

### ■ Truss Frame Section

### ■ Hand Winch Section

## TRUSS SCREED FRAME ORIENTATION

Figure 14 shows how to determine the left, right, front and rear of a screed frame truss section.

The right side of the screed truss frame will be stamped with the letter "R" and the left side will be stamped with the letter "L". In addition the front of the screed will have two screed blades attached to the truss frame, while the rear of the truss frame has only one bullfloat blade.

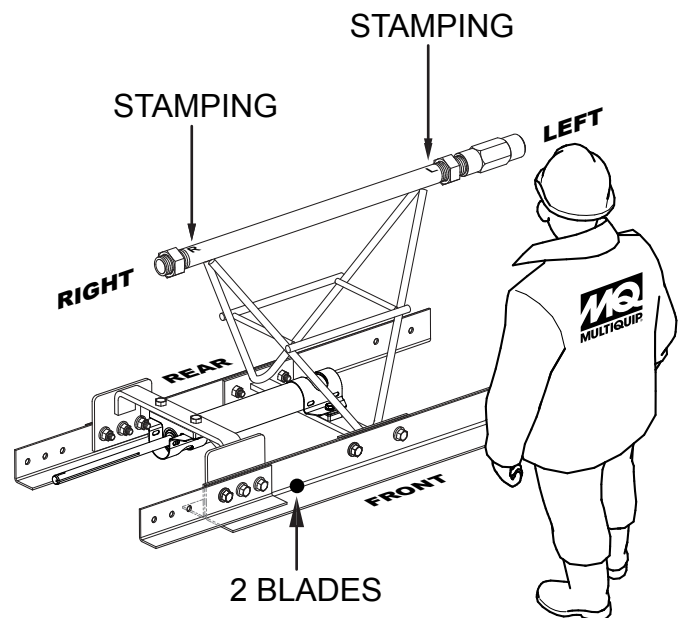
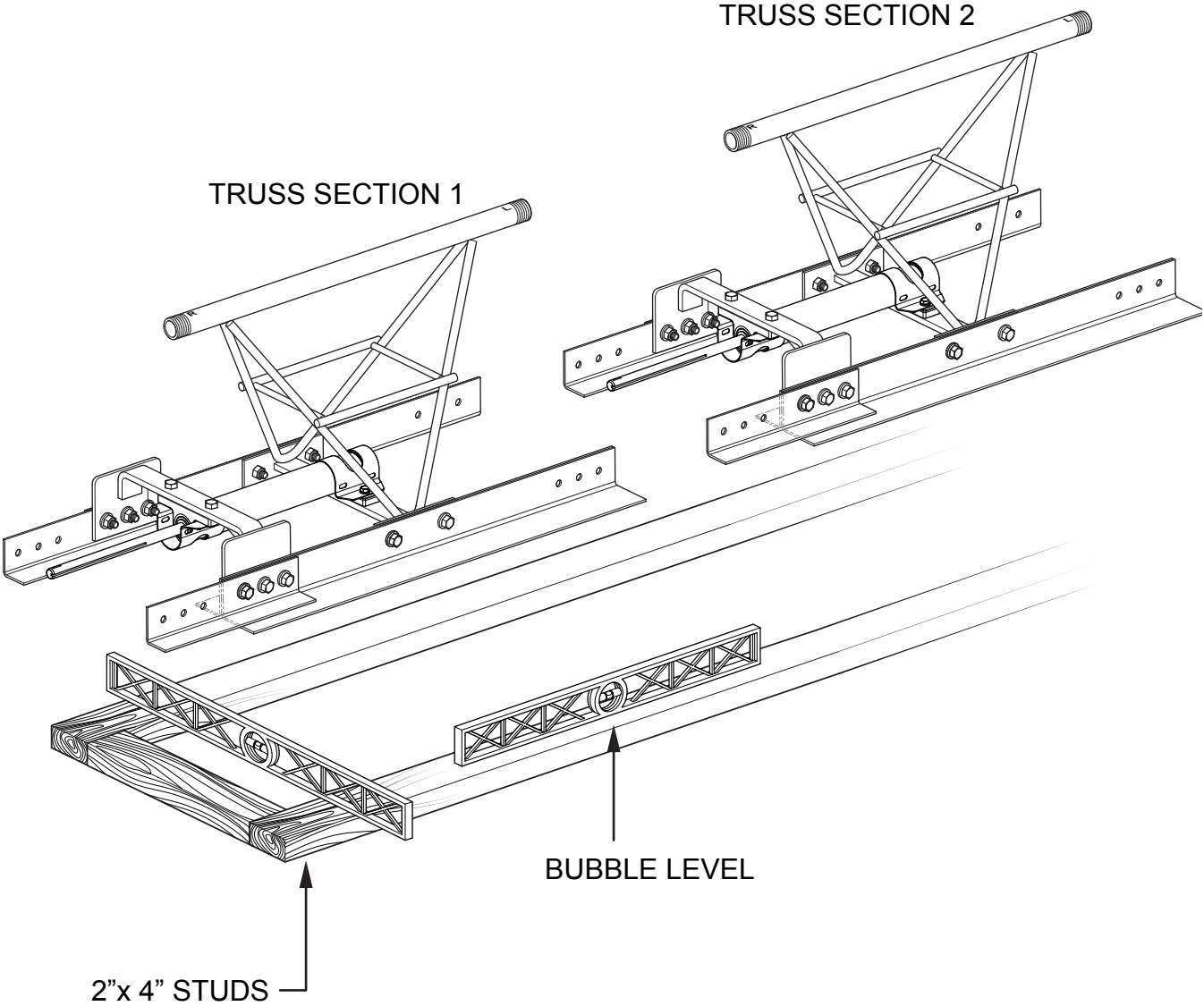

Figure 14. Screed Orientation

**PLATFORM ASSEMBLY**

Place all individual screed sections (Figure 15) to be assembled on level ground. If ground is unlevelled, use a 2" x 4" piece of wood under each section to be joined. The use of a level may be required.



**Figure 15. Assembly Platform**

---

## CONNECTING THE TRUSS FRAME SECTIONS

Connect the truss sections as defined by the following procedure.

1. Remove pre-installed mounting hardware from the ends of each screed section (blade connector). This hardware will be used for the attachment of the blade connector.
2. Screw jam nuts onto top pipe as shown in Figure 16. Hand thread the top pipe turnbuckle about 3 turns onto the top pipe of the mating truss section.
3. Be sure to connect the drive shafts of each truss section by means of a drive shaft coupler. Reference eccentric shaft section in this manual.
4. Reinstall blade connector mounting hardware and torque all bolts to 70 ft.-lbs. (95 N·m).
5. Pull each screed section together until top the turnbuckle connects at the top pipe. Each section is marked with an "L" for left-hand thread and an "R" for right-hand thread.
6. To prevent cross-threading, start the turnbuckle by hand.
7. While tightening the turnbuckle, the sections will pull together. As the sections come together, turn the turnbuckle only enough to make sure that the 2 screed blades in front and the bull float blade just make light contact

## CONNECTING THE ECCENTRIC SHAFT SECTIONS

1. Each truss section has an eccentric shaft. The shaft of one section must be connected to the adjoining truss section until the desired length of screed is achieved.
2. The connection of multiple eccentric shafts is achieved by the use of a drive shaft coupler.
3. Starting from the initial truss frame, remove the tube mount/cover and associated hardware. This will allow for easy access to the pillow block bearing.
4. Next, verify that the drive shaft coupler has already been installed on the free end of the drive shaft as shown in Figure 16.
5. If the coupler is not installed, please install coupler. Reference parts manual for coupler part number.
6. It may be necessary to loosen the set screws on the coupler so that the coupler will slide onto the adjoining drive shaft easily.
7. Insert the drive shaft from the adjoining truss frame into the free end of the coupler.
8. Once both shafts have been inserted and centered into the coupler, apply Loctite™ to the set screws and tighten set screws to 30 ft.-lbs. (41 N·m).
9. Repeat the above steps for each section of screed that will be joined together.

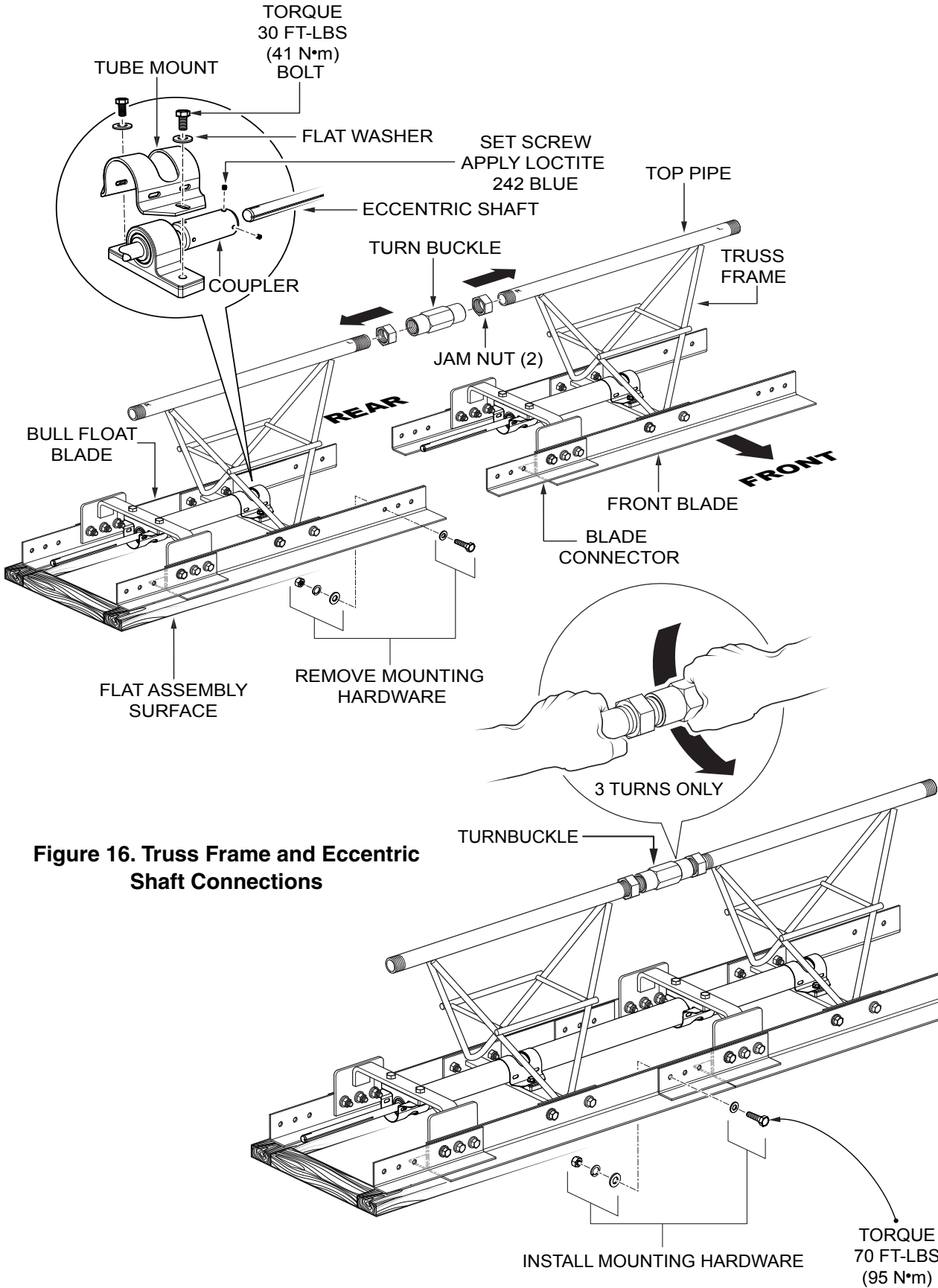

**Figure 16. Truss Frame and Eccentric Shaft Connections**

## WINCH INSTALLATION

Screed travel is accomplished by the means of manually operated winches. There is one winch located on each end of the screed. The winch assembly should already be installed on the end handle frame section.

If the winch assembly is not installed on the end handle frame section, mount the winch as shown in Figure 17.

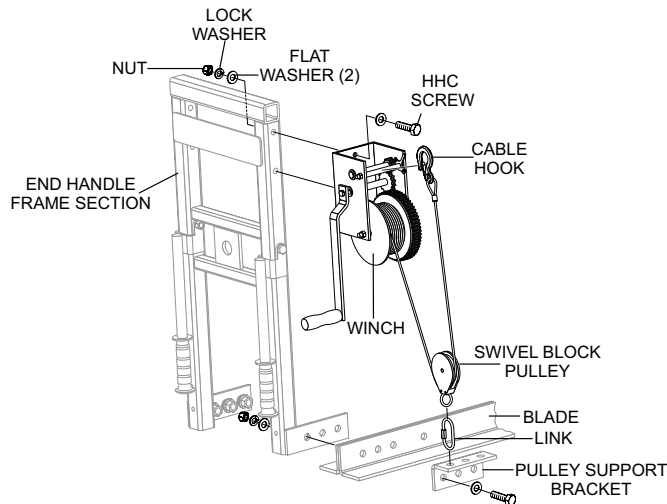

Figure 17. Winch Installation

## ATTACHING FORM STAKES

Form stakes are required to secure the winch cables. To prevent injury it is very important to make sure the winch cables are properly attached to the form stakes.

Figure 18 illustrates the correct method of attaching the winch cables to the form stakes. If the winch cables are not attached to the form stakes correctly, the cables could snap loose causing severe bodily harm and damage to the equipment.

The following procedure outlines the correct procedure for attaching the winch cable to the form stakes:

1. Insert stake between the stake support strap and form. Hammer stake into the ground at least 2 ft. (0.6 meters). Make sure stake has been driven firmly into the ground and will not pull out when tension is applied.
2. Loop the hook end of the winch cable around the first stake from the end of the form as shown in Figure 18. Make sure you go underneath the form.

3. Continue pulling the winch cable and connect the hook portion of the winch cable to the second stake.

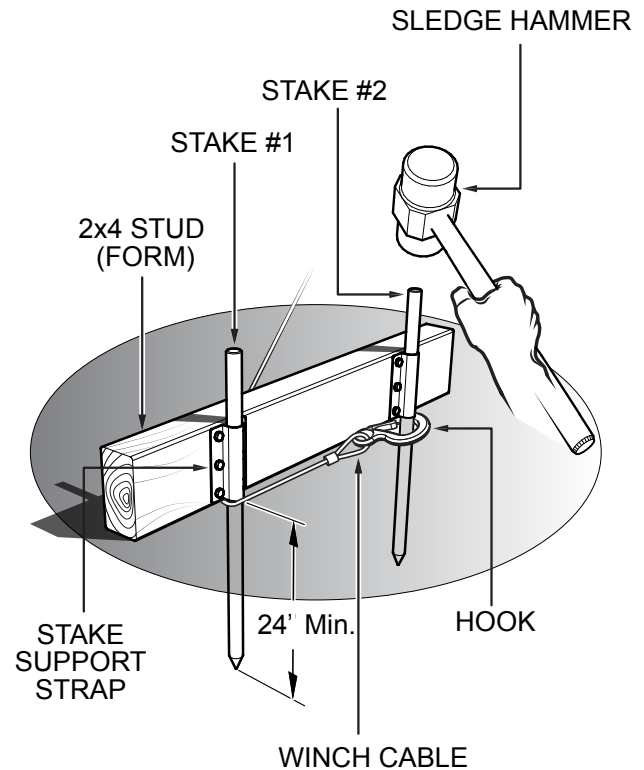

Figure 18. Attaching Winch Stakes

### **! DANGER**

#### **WINCH STAKES**

**DO NOT** hook winch cables to a stake driven directly into the ground. Stake should be installed as shown in Figure 18. The stake can tilt and allow winch cable under tension to snap and break free causing severe bodily harm and damage to equipment.

### **! DANGER**

#### **WINCH CABLES**

**NEVER** operate screed with worn, frayed or damaged winch cables. Winch cables under tension may snap and break free causing severe bodily harm and damage to equipment.

## CONNECTING THE END HANDLE AND ENGINE FRAME SECTIONS

1. The end handle and engine truss frame sections are pre-assembled. Simply connect one end of engine truss frame as shown in Figure 19
2. Thread adapter onto top pipe of engine truss frame section.
3. Align end handle section with engine truss frame section. Use blade connector to mate the two sections.
4. Next, insert bolt and washer into adapter and tighten securely.
5. Connect the free end of engine truss frame to the adjoining truss frame by means of a turnbuckle and drive shaft coupler.

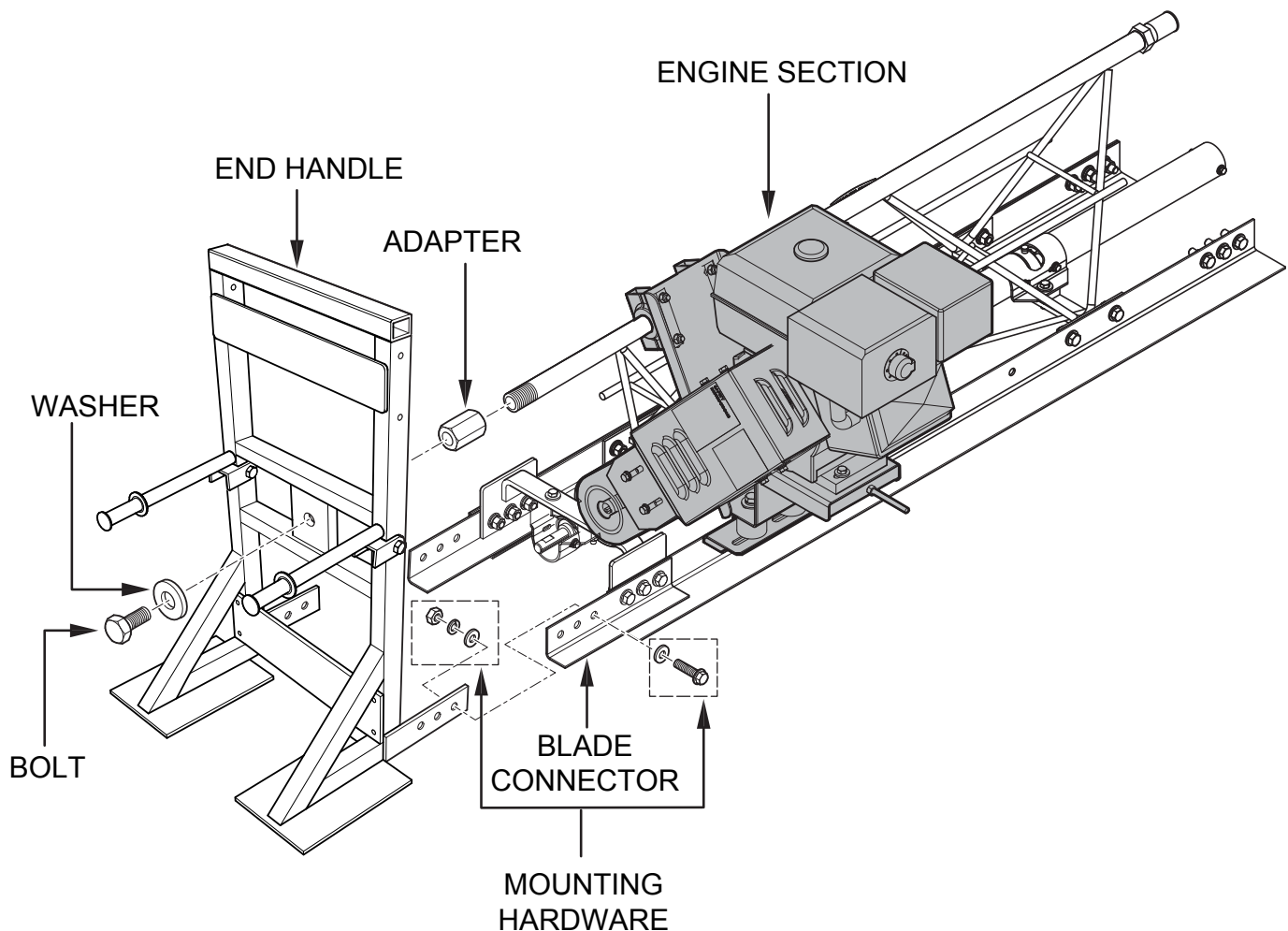

Figure 19. Mating End Handle and Engine Sections



## BLADE ALIGNMENT

Once the entire screen length (end handles, truss frame sections and engine) has been assembled final alignment of the blades can begin. Use the following procedure for blade alignment.

1. Place screed ends on a flat wooden support. Reference Figure 20.
2. At approximately 1-inch (2.54 cm.) out from the leading edge from the screed blade, drive a nail into the wooden support. Nail should be on outside of support.
3. Attach a piece of string to the nail by tying a knot around the nail.
4. Stretch the string line as tight as possible and connect it to the nail at the other end of screed by tying a knot around the nail.
5. Make sure that the nail is contacting each support at the point of blade contact.
6. Use a short, flat piece of metal or wood as a gauge to compare the string to the bottom surface of the screed blade and bullfloat blades at the splice point.

The string should just make contact with the metal/wood gauge if the blades have been aligned properly. If the string does not make contact with the gauge, realignment is required.

7. The blades should be of equal height at each splice point. If the height of the blades are not even, turn the turnbuckle in a direction that achieves equal height for both blades at the splice point.
8. Once all the blades have been aligned correctly, tighten jam nuts on top pipe to prevent turnbuckle from rotating during operation.
9. The screed is now ready for operation. Lift screed onto form.

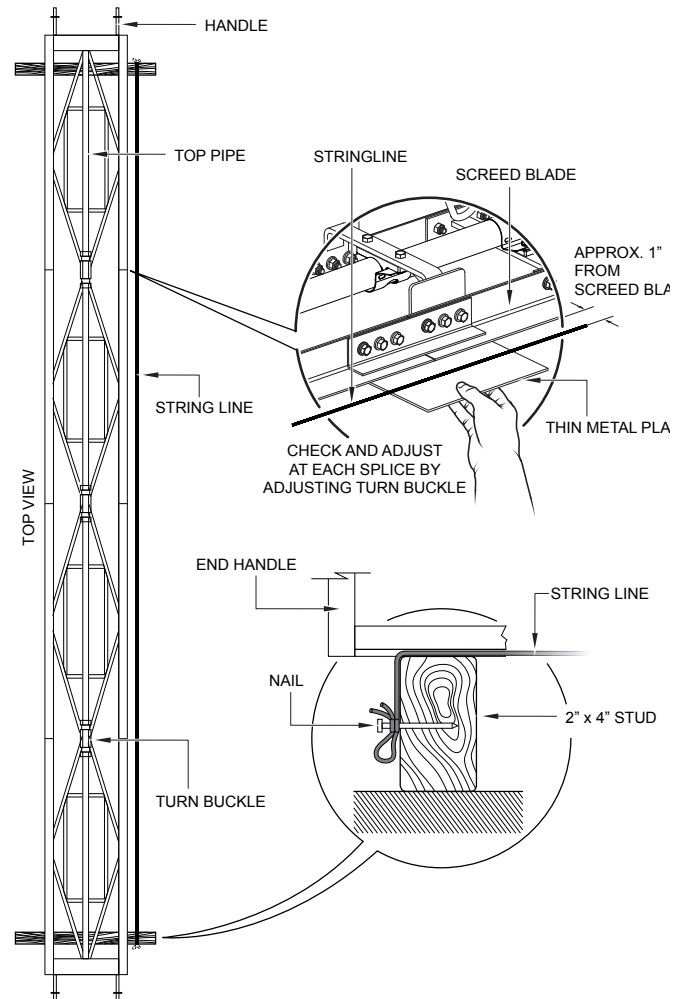

**Figure 20. Blade Alignment**

## CAUTION



**DO NOT** attempt to operate this vibratory screed until the Safety Information, General Information, and Inspection sections of this manual have been *read and thoroughly understood*.

## STARTING

1. Place the engine fuel lever to the **ON** position. (Figure 21).

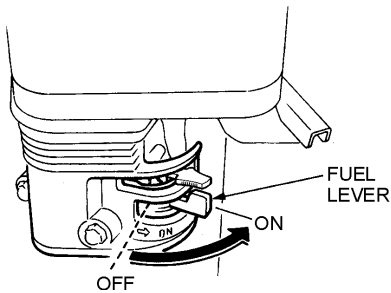

**Figure 21. Engine Fuel Lever (ON Position)**

2. Place the choke lever (Figure 22) in the **CLOSED** position if starting a cold engine.

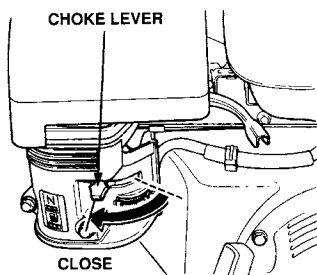
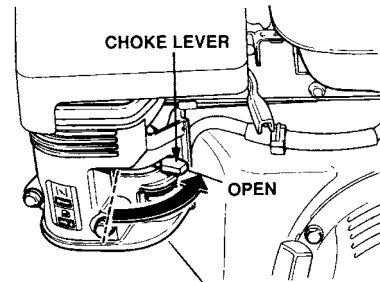

**Figure 22. Engine Choke Lever (Closed)**

## NOTICE

The **CLOSED** position of the choke lever enriches the fuel mixture for starting a cold engine. The **OPEN** position provides the correct fuel mixture for normal operation after starting, and for restarting a warm engine.

3. Place the choke lever (Figure 23) in the **OPEN** position if starting a warm engine or the temperature is warm.



**Figure 23. Engine Choke Lever (Open)**

4. Move the throttle lever halfway between the **FAST** and **SLOW** position (Figure 24) for starting.

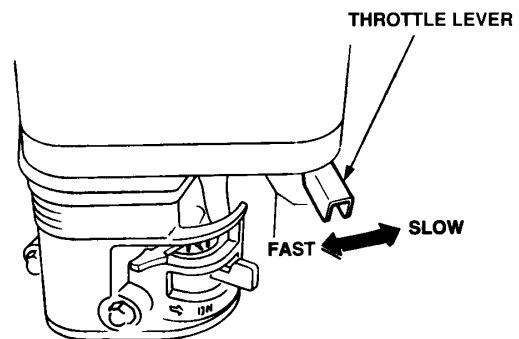

**Figure 24. Throttle Lever**

5. Place the engine ON/OFF switch (Figure 25) in the **ON** position.

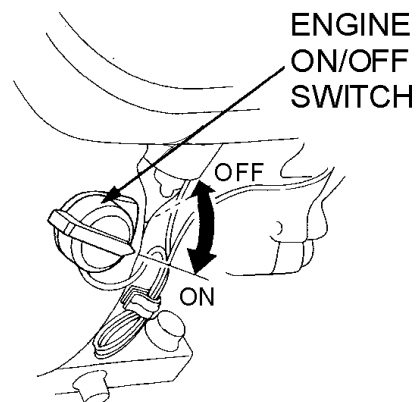

**Figure 25. Engine ON/OFF Switch**

6. Grasp the starter grip (Figure 26) and slowly pull it out. The resistance becomes the hardest at a certain position, corresponding to the compression point. Pull the starter grip briskly and smoothly for starting.

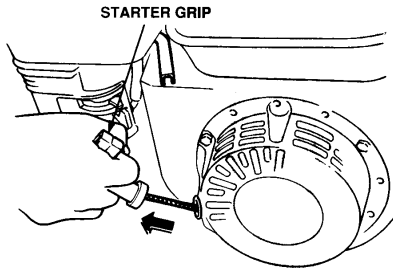

**Figure 26. Starter Grip**

7. Run the engine for several minutes and check for fuel leaks, and noises that would associate with a loose guard or cover.
8. After the engine has warmed, place the choke lever in the **OPEN** position (Figure 27) before operating the screed.

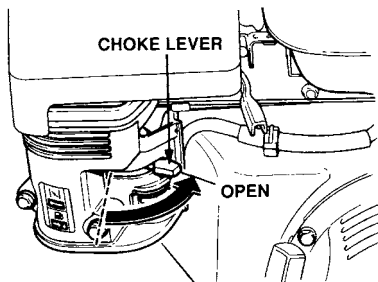

**Figure 27. Engine Choke Lever (Open)**

## NOTICE

**DO NOT** pull the starter rope all the way to the end. **DO NOT** release the starter rope after pulling. Allow it to rewind as soon as possible.

## ENGINE DRIVEN SCREED

1. Engage or turn winch handles simultaneously to keep screed even.

## NOTICE

**NEVER** let the concrete build up on the front blade. This causes the screed to be stressed and is strenuous on the operators controlling the manual winches. The concrete should not go above the bolts attaching the blades. If this happens, stop the screed and let the vibration do its job.

2. If the concrete is not being added at the appropriate rate, slow down the screed to compensate.
3. The speed that the screed should be operated at is determined by the slump of the concrete. Pay close attention to the aggregates, slump, and concrete modifying agents so that you can compensate for them.

## NOTICE

**REMINDER: DO NOT** over-vibrate the concrete.

4. After completion of the pours, make sure to clean the screed immediately to prevent concrete from curing on the drive shaft and bearings.

## STOPPING THE ENGINE

## CAUTION

**NEVER** stop the engine suddenly while working at high speeds.

1. Place the throttle lever (Figure 24) in slow position, and listen for the engine speed to decrease.
2. Let engine idle for 3-5 minutes.
3. Place the Engine ON/OFF switch (Figure 25) in the "**OFF**" position.
4. Place the fuel valve lever (Figure 21) in the "**OFF**" position.

# MAINTENANCE

**Table 6. Engine Maintenance Schedule**

DESCRIPTION (3)	OPERATION	BEFORE EACH USE	FIRST MONTH OR 20 HRS.	EVERY 6 MONTHS OR 100 HRS.	EVERY YEAR OR 300 HRS.	EVERY 2 YEARS OR 500 HRS.
Engine Oil	Check	X				
	Change		X	X		
Engine Oil Filter	Replace	Every 200 Hrs.				
Air Cleaner	Check	X				
	Clean			X (1)		
	Change					X (*)
Spark Plugs	Check/Adjust			X		
	Replace				X	
Spark Arrester	Clean			X		
Fuel Filter	Replace				X (2)	
Fuel Tube	Check	Every 2 years (replace if necessary) (2)				

\* - Replace the paper filter element only.

(1) Service more frequently when used in **DUSTY** areas.

(2) These items should be serviced by your service dealer, unless you have the proper tools and are mechanically proficient. Refer to the HONDA Shop Manual for service procedures.

(3) For commercial use, log hours of operation to determine proper maintenance intervals.

**Table 7. Sced Maintenance Schedule**

ITEM	OPERATION	DAILY	Periodic Maintenance Interval			
			Every 10 Hrs	Every 40-50 Hrs	Every 200-300 Hrs	Every 2000-2500 Hrs
V-Belt	Check/Replace	X				
Relube Bearings	Grease			X		
Blades	Check/Replace			X		
Winch Bushings	Lubricate		X		X	
Winch Cable	Check/Clean			X	X	
Eccentric Shaft	Check			X		X
Eccentric Shaft Weights	Checks/Replace			X		X
Truss Frame	Clean	X				X

General maintenance practices are crucial to the performance and longevity of your screed. This equipment requires routine cleaning, blade and trowel arm inspection, lubrication and V-belt inspection for wear and damage. Reference Table 6 and Table 7 for scheduled engine and screed maintenance.

The following procedures, devoted to maintenance, can prevent serious screed damage or malfunctioning.

## NOTICE

Reference **HONDA** engine manual supplied with your trowel for more detailed engine maintenance and troubleshooting.

## CAUTION



**ALWAYS** allow the engine to cool before servicing. **NEVER** attempt any maintenance work on a hot engine.

## CAUTION

**ALWAYS** disconnect the spark plug wire from the spark plug and secure away from the engine before performing maintenance or adjustments on the machine.

## WARNING



Some maintenance operations may require the engine to be run. Ensure that the maintenance area is well ventilated. Gasoline engine exhaust contains poisonous carbon monoxide gas that can cause unconsciousness and may result in **DEATH**.

## GENERAL CLEANLINESS

Clean the screed daily. Remove all dust and slurry buildup. If the screed is steam-cleaned, ensure that lubrication is accomplished **AFTER** steam cleaning.

## ENGINE CHECK

Check daily for any oil and/or fuel leakage, thread nut and bolt tightness, and overall cleanliness.

## Engine Air Cleaner

### DANGER



**DO NOT** use gasoline or low flash point solvents for cleaning the air cleaner, the possibility exists of fire or explosion which can cause damage to the equipment and severe bodily harm or even **DEATH!**

### CAUTION



Wear protective equipment such as approved safety glasses or face shields and dust masks or respirators when cleaning air filters with compressed air.

This engine is equipped with a replaceable, high-density paper air cleaner element. See Figure 28 for air cleaner components.

1. Remove the air cleaner cover and foam filter element.
2. Tap the paper filter element several times on a hard surface to remove dirt, or blow compressed air not exceeding 30 psi (207 kPa, 2.1 kgf/cm<sup>2</sup>) through the filter element from the inside out. **NEVER** brush off dirt. Brushing will force dirt into the fibers. Replace the paper filter element if it is excessively dirty.
3. Clean foam element in warm, soapy water or nonflammable solvent. Rinse and dry thoroughly. Dip the element in clean engine oil and completely squeeze out the excess oil from the element before installing.

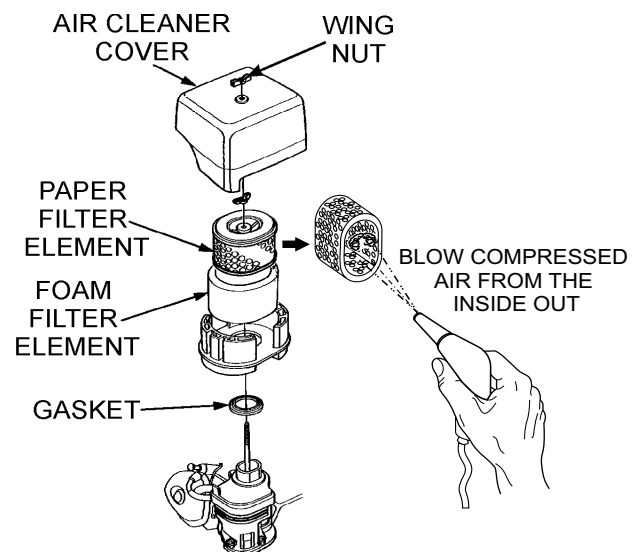

Figure 28. Engine Air Cleaner

## NOTICE

Operating the engine with loose or damaged air cleaner components could allow unfiltered air into the engine causing premature wear and failure.

## ENGINE OIL

1. Drain the engine oil when the oil is warm as shown in Figure 29.
2. Remove the oil drain bolt and sealing washer and allow the oil to drain into a suitable container.
3. Replace engine oil with recommended type oil as listed in Table 5. For engine oil capacity, see Table 4 (engine specifications). **DO NOT** overfill.
4. Reinstall drain bolt with sealing washer and tighten securely.

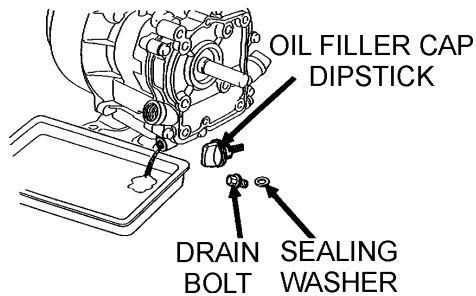

Figure 29. Draining Engine Oil

## SPARK PLUG

### NOTICE

**NEVER** use a spark plug of incorrect heat range.

1. Remove and clean spark plug (Figure 30) with a wire brush if it is to be reused. Discard spark plug if the insulator is cracked or chipped.
2. Using a feeler gauge adjust spark plug gap to 0.028 ~0.031 inch (0.7~0.8 mm).
3. Thread spark plug into cylinder hole by hand to prevent cross-threading, then tighten securely.

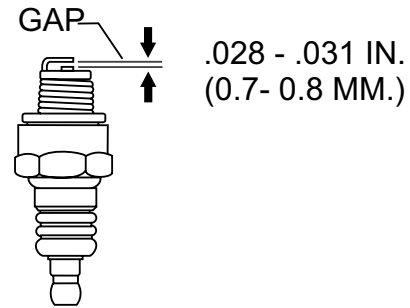

Figure 30. Spark Plug Gap

## V-BELT

Visually examine the V-belt (Figure 31) and determine if it is full of tiny cracks, frayed, has pieces of rubber missing, is peeling or otherwise damaged.

Also, examine the belt and determine if it is **oil soaked** or "**glazed**" (hard shiny appearance on the sides of the belt). Either of these two conditions can cause the belt to run hot, which can weaken it and increase the danger of it breaking.

If the V-belt exhibits any of the above wear conditions replace the V-belt immediately.

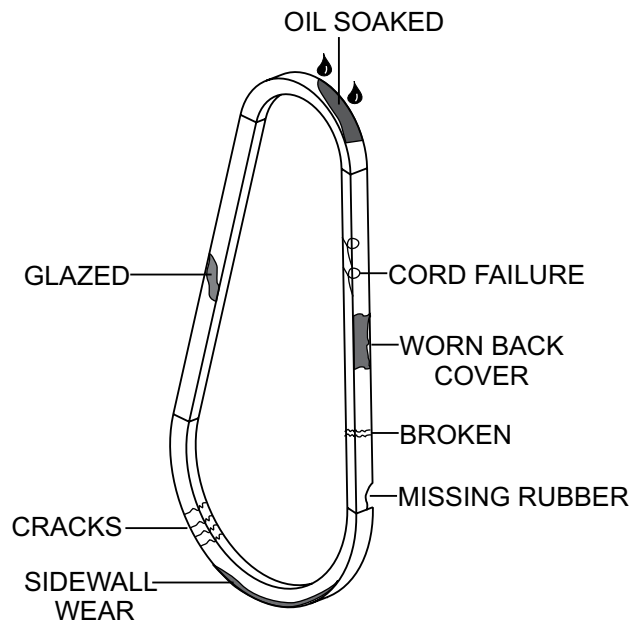
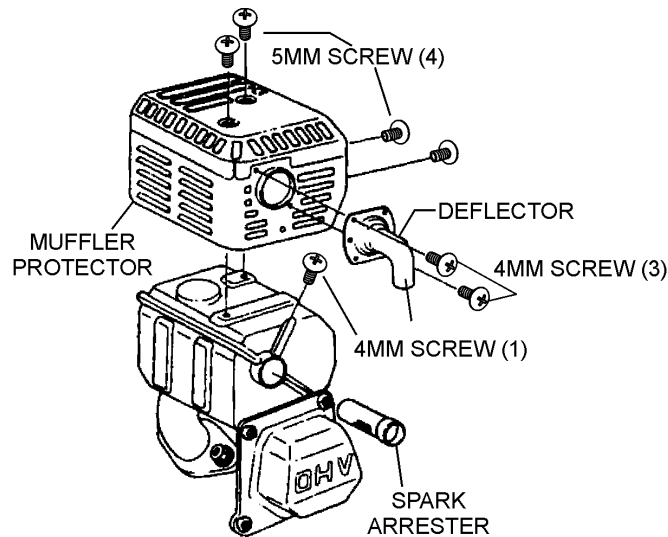

Figure 31. V-Belt Inspection

## SPARK ARRESTER CLEANING

Clean the spark arrester every 6 months or 100 hours.

1. Remove the 4 mm screw (3) from the exhaust deflector, then remove the deflector. See Figure 32
2. Remove the 5 mm screw (4) from the muffler protector, then remove the muffler protector.
3. Remove the 4 mm screw from the spark arrester, then remove the spark arrester.



**Figure 32. Spark Arrester Removal**

4. Carefully remove carbon deposits from the spark arrester screen (Figure 33) with a wire brush.

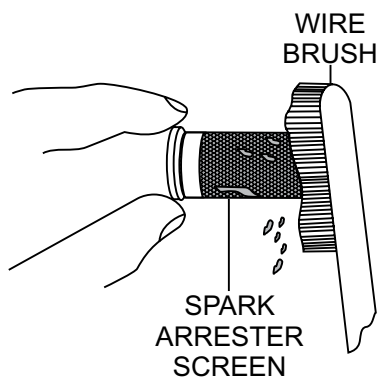
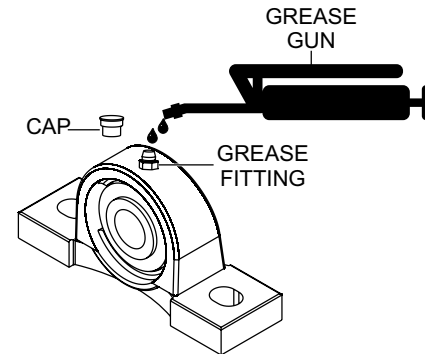

**Figure 33. Cleaning The Spark Arrester**

5. If the spark arrester is damaged and has breaks or holes, replace with a new one.
6. Reinstall the spark arrester and muffler protector in reverse order of disassembly.

## SPARK ARRESTER CLEANING

Each truss section has a set of pillow block bearings (Figure 34) that will require lubrication. Lubricate the grease fitting for each bearing every 40 hours of operation using any grade lithium base grease



**Figure 34. Bearing Maintenance**

### NOTICE

**Failure** to keep bearings lubricated (greased) will cause rotation of eccentric drive shaft to stiffen. To prevent contamination of the bearing, always insert the protective cap onto the bearing grease fitting.

## ECCENTRIC SHAFT WEIGHTS ORIENTATION

Orientation of the eccentric shaft weights (Figure 35) must be aligned so that the fat side of the weight is in line (parallel) with the drive shaft key way.

For proper vibration of the shaft, all eccentric weights must be aligned identically.

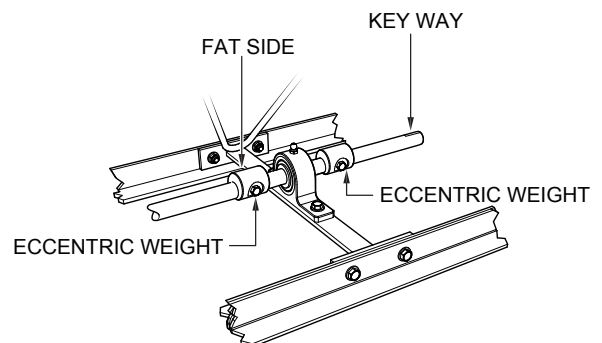

**Figure 35. Eccentric Shaft Weight Orientation**

## LONG TERM STORAGE

For storage of the screed for over 30 days, the following is recommended:

- Drain fuel tank completely, or add STA-BIL to the fuel.
- Run the engine until the fuel is completely consumed.
- Completely drain used oil from the engine crankcase and fill with fresh clean oil, then follow the procedures as described in the engine manual for engine storage.
- Clean the entire screed.
- Store unit covered with plastic sheet in a dust-free location out of direct sunlight.
- All disposals must be in accordance with federal, state and local regulations.





# TROUBLESHOOTING

Troubleshooting (Engine)		
Symptom	Possible Problem	Solution
Difficult to start, fuel is available, but no spark at spark plug.	Spark plug bridging?	Check gap, insulation or replace spark plug.
	Carbon deposit on spark plug?	Clean or replace spark plug.
	Short circuit due to deficient spark plug insulation?	Check spark plug insulation, replace if worn.
	Improper spark plug gap?	Set to proper gap.
	Fuel reaching carburetor?	Check fuel line.
	Water in fuel tank?	Flush or replace fuel tank.
	Fuel filter clogged?	Replace fuel filter.
	Stuck carburetor?	Check float mechanism.
	Spark plug is red?	Check transistor ignition unit.
	Spark plug is bluish white?	If insufficient compression, repair or replace engine. If injected air leaking, correct leak. If carburetor jets clogged, clean carburetor.
	No spark present at tip of spark plug?	Check transistor ignition unit is broken, and replace defective unit. Check if voltage cord cracked or broken and replace. Check if spark plug if fouled and replace.
	No oil?	Add oil as required.
	Oil pressure alarm lamp blinks upon starting? (if applicable)	Check automatic shutdown circuit, "oil sensor". (if applicable)
Difficult to start, fuel is available, and spark is present at the spark plug.	ON/OFF switch is shorted?	Check switch wiring, replace switch.
	Ignition coil defective?	Replace ignition coil.
	Improper spark gap, points dirty?	Set correct spark gap and clean points.
	Condenser insulation worn or short circuiting?	Replace condenser.
	Spark plug wire broken or short circuiting?	Replace defective spark plug wiring.
Difficult to start, fuel is available, spark is present and compression is normal.	Wrong fuel type?	Flush fuel system, and replace with correct type of fuel.
	Water or dust in fuel system?	Flush fuel system.
	Air cleaner dirty?	Clean or replace air cleaner.
	Choke open?	Close choke.
Difficult to start, fuel is available, spark is present and compression is low.	Suction/exhaust valve stuck or protruded?	Reseat valves.
	Piston ring and/or cylinder worn?	Replace piston rings and/or piston.
	Cylinder head and/or spark plug not tightened properly?	Torque cylinder head bolts and spark plug.
	Head gasket and/or spark plug gasket damaged?	Replace head and spark plug gaskets.
No fuel present at carburetor.	No fuel in fuel tank?	Fill with correct type of fuel.
	Fuel cock does not open properly?	Apply lubricant to loosen fuel cock lever, replace if necessary.
	Fuel filter/lines clogged?	Replace fuel filter.
	Fuel tank cap breather hole clogged?	Clean or replace fuel tank cap.
	Air in fuel line?	Bleed fuel line.

# TROUBLESHOOTING

<b>Troubleshooting (Engine) - continued</b>		
<b>Symptom</b>	<b>Possible Problem</b>	<b>Solution</b>
Weak in power, compression is proper and does not misfire.	Air cleaner dirty?	Clean or replace air cleaner.
	Improper level in carburetor?	Check float adjustment, rebuild carburetor.
	Defective spark plug?	Clean or replace spark plug.
	Improper spark plug?	Set to proper gap.
Weak in power, compression is proper but misfires.	Water in fuel system?	Flush fuel system and replace with correct type of fuel.
	Dirty spark plug?	Clean or replace spark plug.
	Ignition coil defective?	Replace ignition coil.
Engine overheats.	Spark plug heat value incorrect?	Replace with correct type of spark plug.
	Wrong type of fuel?	Replace with correct type of fuel.
	Cooling fins dirty?	Clean cooling fins.
	Intake air restricted?	Clear intake of dirt and debris. Replace air cleaner elements as necessary.
	Oil level too low or too high?	Adjust oil to proper level.
Rotational speed fluctuates.	Governor adjusted incorrectly?	Adjust governor.
	Governor spring defective?	Replace governor spring.
	Fuel flow restricted?	Check entire fuel system for leaks or clogs.
Recoil starter malfunctions. (if applicable)	Recoil mechanism clogged with dust and dirt?	Clean recoil assembly with soap and water.
	Spiral spring loose?	Replace spiral spring.
Starter malfunctions.	Loose, damaged wiring?	Ensure tight, clean connections on battery and starter.
	Battery insufficiently charged?	Recharge or replace battery.
	Starter damaged or internally shorted?	Replace starter.
Burns too much fuel.	Over-accumulation of exhaust products?	Check and clean valves. Check muffler and replace if necessary.
	Wrong spark plug?	Replace spark plug with manufacturer's suggested type.
Exhaust color is continuously "white".	Lubricating oil is wrong viscosity?	Replace lubricating oil with correct viscosity.
	Worn rings?	Replace rings.
Exhaust color is continuously "black".	Air cleaner clogged?	Clean or replace air cleaner.
	Choke valve set to incorrect position?	Adjust choke valve to correct position.
	Carburetor defective, seal on carburetor broken?	Replace carburetor or seal.
Will not start, no power with ON/OFF switch in "ON" position.	Poor carburetor adjustment, engine runs too rich?	Adjust carburetor.
	ON/OFF switch not activated ON?	Turn on ON/OFF Switch.
	ON/OFF switch/wiring defective?	Replace ON/OFF switch. Check wiring.
	Centrifugal stop switch not activated ON?	Turn on centrifugal stop switch.
	Centrifugal stop switch/wiring defective?	Replace centrifugal stop switch. Check wiring.



# OPERATION MANUAL

## HERE'S HOW TO GET HELP

PLEASE HAVE THE MODEL AND SERIAL  
NUMBER ON-HAND WHEN CALLING

### UNITED STATES

#### ***Multiquip Corporate Office***

18910 Wilmington Ave.  
Carson, CA 90746  
Contact: mq@multiquip.com

Tel. (800) 421-1244  
Fax (310) 537-3927

#### ***Service Department***

800-421-1244  
310-537-3700

Fax: 310-537-4259

#### ***Technical Assistance***

800-478-1244

Fax: 310-943-2238

#### ***MQ Parts Department***

800-427-1244  
310-537-3700

Fax: 800-672-7877  
Fax: 310-637-3284

#### ***Warranty Department***

800-421-1244  
310-537-3700

Fax: 310-943-2249

---

### MEXICO

#### ***MQ Cipsa***

Carr. Fed. Mexico-Puebla KM 126.5  
Momoxpan, Cholula, Puebla 72760 Mexico  
Contact: pmastretta@cipsa.com.mx

Tel: (52) 222-225-9900  
Fax: (52) 222-285-0420

### CANADA

#### ***Multiquip***

4110 Industriel Boul.  
Laval, Quebec, Canada H7L 6V3  
Contact: jmartin@multiquip.com

Tel: (450) 625-2244  
Tel: (877) 963-4411  
Fax: (450) 625-8664

---

### UNITED KINGDOM

#### ***Multiquip (UK) Limited Head Office***

Unit 2, Northpoint Industrial Estate,  
Globe Lane,  
Dukinfield, Cheshire SK16 4UJ  
Contact: sales@multiquip.co.uk

Tel: 0161 339 2223  
Fax: 0161 339 3226

© COPYRIGHT 2012, MULTIQUIP INC.

Multiquip Inc, the MQ logo and the Whiteman logo are registered trademarks of Multiquip Inc. and may not be used, reproduced, or altered without written permission. All other trademarks are the property of their respective owners and used with permission.

This manual MUST accompany the equipment at all times. This manual is considered a permanent part of the equipment and should remain with the unit if resold.

The information and specifications included in this publication were in effect at the time of approval for printing. Illustrations, descriptions, references and technical data contained in this manual are for guidance only and may not be considered as binding. Multiquip Inc. reserves the right to discontinue or change specifications, design or the information published in this publication at any time without notice and without incurring any obligations.

Your Local Dealer is:



**PN: 36870**