

TLW-300SS —GENERATOR WIRING DIAGRAM

Generator Wiring Diagram

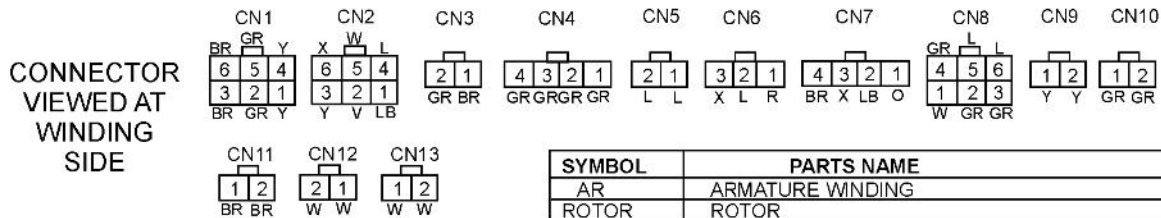
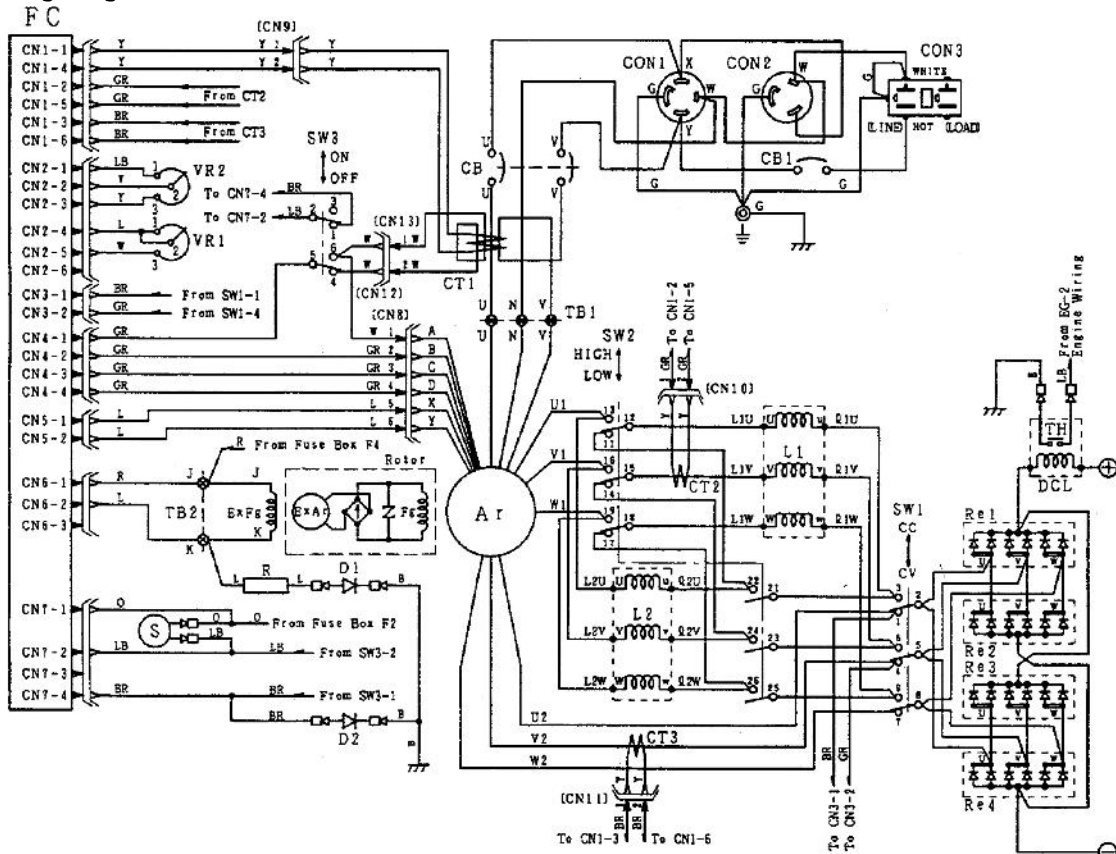

WIRING COLOR CODE	
SYMBOL	COLOR
B	BLACK
L	BLUE
BR	BROWN
G	GREEN
GR	GRAY
V	VIOLET
P	PINK
R	RED
W	WHITE
Y	YELLOW
LB	LIGHT BLUE
LG	LIGHT GREEN
O	ORANGE

COMBINATION TERMINALS

TB1 U N V

TB2 J K AC 50 19 30

SYMBOL	PARTS NAME
AR	ARMATURE WINDING
ROTOR	ROTOR
Fg	FIELD COIL
Ex Ar	ARMATURE EXCITER
Ex Fg	FIELD EXCITER
CON1	RECEPTACLE
CON2	RECEPTACLE
CON3	RECEPTACLE
CB	MAIN CIRCUIT BREAKER (265V, 25 AMP)
CB1	CIRCUIT PROTECTOR (250V, 20 AMP)
SW1	CV/CC SELECTOR SWITCH
SW2	CC CURRENT RANGE SELECTOR SW.
REL 1	RECTIFIER
REL 2,4	RECTIFIER
L1,2	AC REACTOR
DCL	DC REACTOR
TH	THERMOSTAT SWITCH
⊕ ⊖	WELDING OUTPUT TERMINAL
⊥	GROUND TERMINAL
FC	FIELD CONTROL UNIT
CT1~1	CURRENT TRANSFORMER
VR1	CURRENT CONTROL
VR2	VOLTAGE CONTROL
SW3	IDLE CONTROL SWITCH
R	RESISTOR
S	ROTARY SOLENOID
TB1	TERMINAL BOARD
TB2	TERMINAL BOARD

TLW-300SS —ENGINE WIRING DIAGRAM

Engine Wiring Diagram

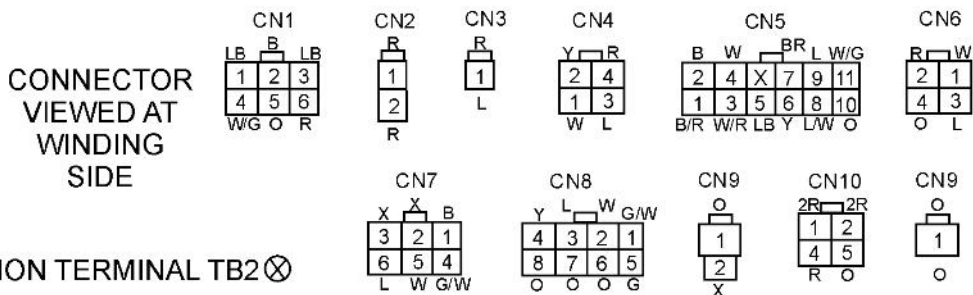
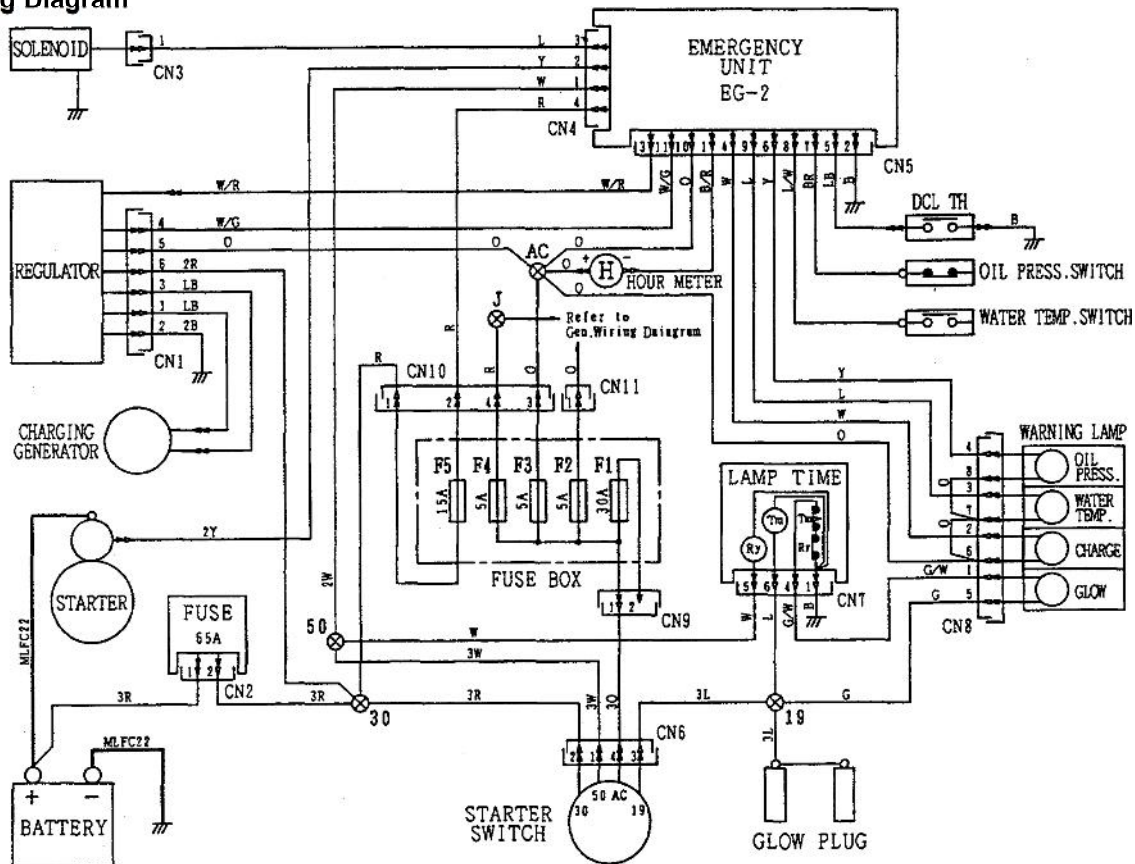

WIRING COLOR CODE	
SYMBOL	COLOR
B	BLACK
L	BLUE
BR	BROWN
G	GREEN
GR	GRAY
V	VIOLET
P	PINK
R	RED
W	WHITE
Y	YELLOW
LB	LIGHT BLUE
LG	LIGHT GREEN
O	ORANGE

