

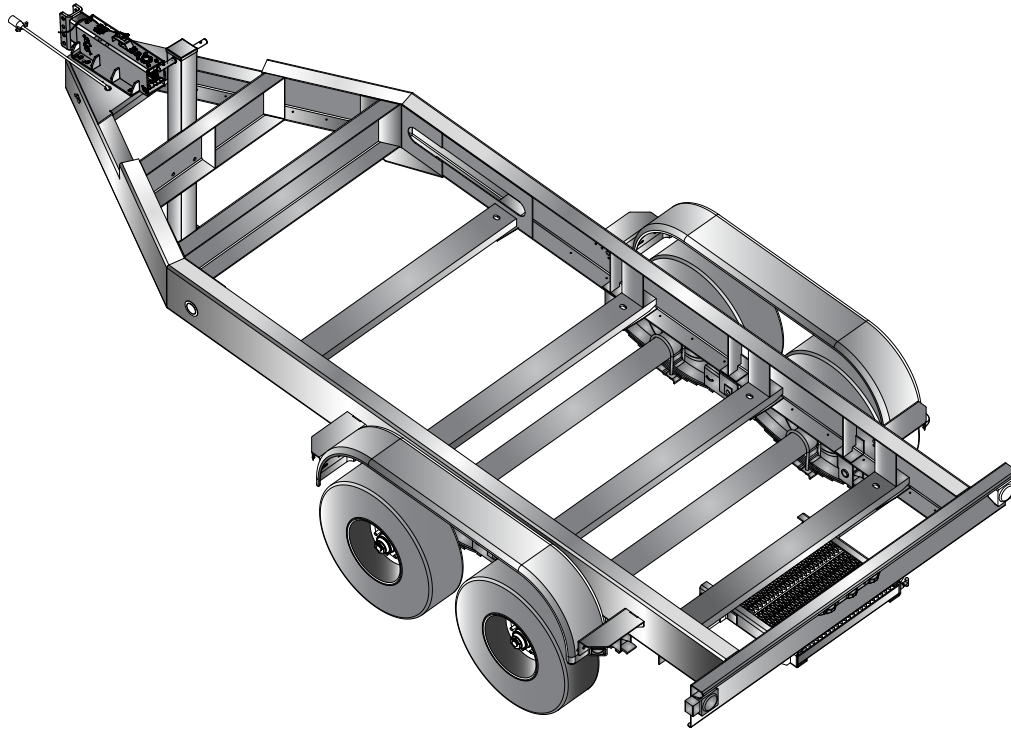

TRLR300EV

MQ POWER Tandem Axle Trailer



TRLR300EV Technical Data

Gross Vehicle Weight Rating (GVWR) — 20,000 lbs (9,071 kg)	Tire Size — 235/75R17.5 LR-J
Gross Axle Weight Rating (GAWR) — 10,000 lbs /4,536 kg (ea.)	Wheel Bolt Pattern — 8 Lug on 6.5 in
Actuator Rating — 20,000 lbs (9,072 kg)	Tire Load Rating — 6,005 lbs /2,724 kg (ea.)
Coupler Rating — See coupler options on back page.	Dimensions (LxWxH) — See back page

STANDARD TRAILER EQUIPMENT

- Fits MQ Power Generator Model DCA300SSJU4F2
- Straight Tandem-axle Design with Leaf Spring Suspension
- Heavy-Duty Welded Steel Frame Construction
- Structural Channel for Generator Mounting and Support
- Replaceable, Bolt-on Hydraulic Brake Actuator
- 4-hole Channel Allows 3-position, Adjustable Coupler Height; 4-inches O/A
- Heavy-duty, Tongue Mounted, Drop-leg Jack (rated 10,000 lbs/4,536 kg lift)
- Replaceable Bolt-on Steel Fenders and Brackets
- Rugged Textured Black Powder-Coated Frame, Channel, Actuator and Fenders
- D.O.T. Approved Tail Lamps, Stop Lamps, Turn Signal Lamps, Side Marker Lamps
- Weatherproof, Rubber Armored, 3-piece Trailer Light Wiring Harness
- Surge Hydraulic-actuated Drum Brakes (all axles)
- Hydraulic Dual-servo Drum Brakes with Backup Solenoid — 12-inch Cluster
- D.O.T. Steel Brake Lines, Brass Tees, and Rubber Hydraulic Brake Hoses
- Heavy-Duty Rear Sliding Step with Spring-Loaded Locking Pin



TRLR300EV

MQ POWER Tandem Axle Trailer

OPTIONAL TRAILER EQUIPMENT

- Bolt-on Electric Brake Coupler Plate with Electric-actuated Drum Brakes (all axles — self-adjusting brake actuators)
- Anti-Theft Wheel Lock
- Electric Breakaway Safety Device (electric-actuated brakes)
- Rear Stabilizer Stands
- Spare Tire with Locking Mount
- 24-inch Cable Storage Box

Coupler Options

3" Pintle Eye
25,000 lbs.

#EE36264



2-5/16" Ball Coupler
20,000 lbs.

#EE56770

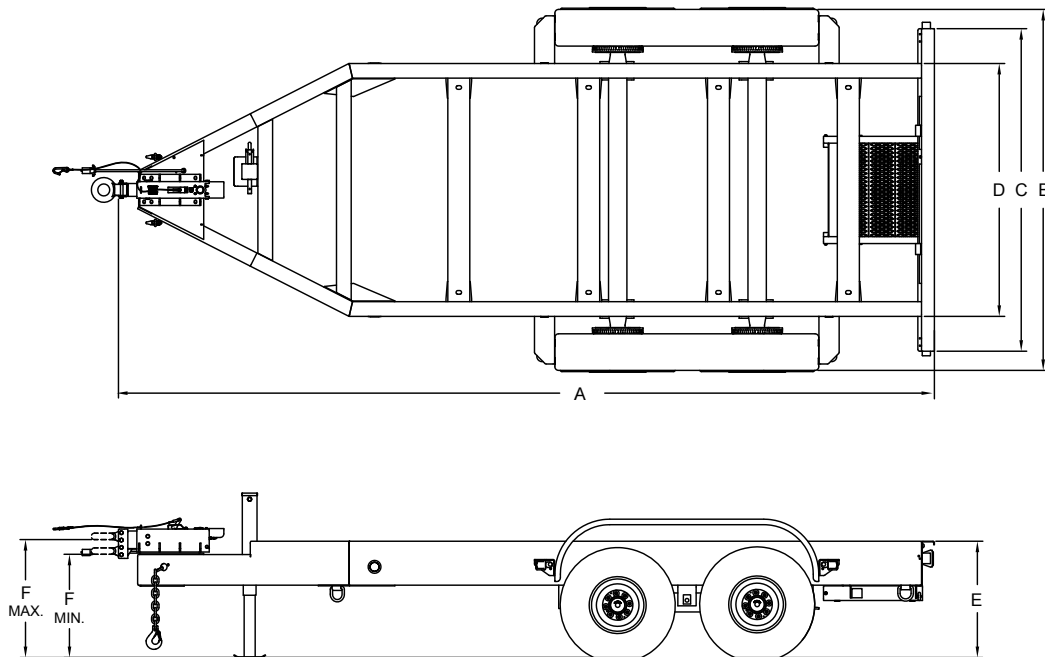
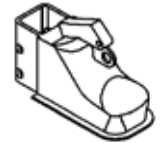

Trailer Dimensions						
A	B	C	D	E	F	
					Min	Max
223.15 in. (5,668 mm)	99.5 in. (2,527 mm)	88 in. (2,235 mm)	69 in. (1,753 mm)	32.95 in. (836 mm)	28.17 in. (715 mm)	32.17 in. (817 mm)

Trailer Weight
3,076 lbs. (1,395 kg)*

* Weight is approximate

Your Multiquip dealer is:

