

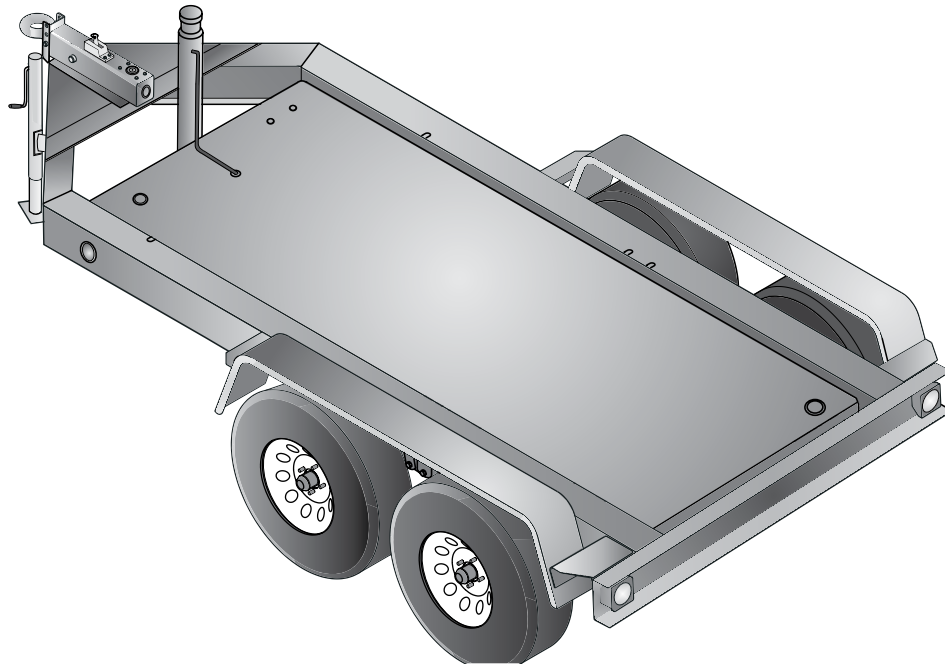

TRLR75XF

MQ POWER Tandem Axle Trailer



TRLR75XF Technical Data

Gross Vehicle Weight Rating (GVWR) — 7,000 lbs (3,175 kg)	Tire Size — ST205/75D15 LR-C
Gross Axle Weight Rating (GAWR) — 3,500 lbs (1,588 kg) (ea.)	Wheel Bolt Pattern — 5 Lug on 4.5 in
Actuator Rating — 8,000 lbs (3,629 kg)	Tire Load Rating — 1,820 lbs/826 kg (ea.)
Coupler Rating — See coupler options on back page	Dimensions (LxWxH) — See back page

STANDARD TRAILER EQUIPMENT

- Fits MQ Power Generator Models DCA36SPX, DCA45SSI, DCA56SPX, DCA70SSI, DCA85SSJ
- Tandem-axle Design with Spring Type Suspension
- H.D. Welded Steel Frame Construction
- Formed Channel for Generator Mounting and Support
- Integral Fuel Cell; Single-wall Steel Design, 100 Gallon Capacity
- Replaceable, Bolt-on Hydraulic Brake Actuator
- Surge Hydraulic-actuated Drum Brakes (all axles)
- Hydraulic Uni-servo Drum Brakes with Free-backing Plates-10-inch Cluster
- D.O.T. Steel Brake Lines, Brass Tees & Rubber Hydraulic Brake Hoses
- 4-hole Channel Allows 3-position, Adjustable Coupler Height; 4-inches O/A
- Tongue Mounted Swivel Jack with Flat Disc-foot (rated 3,000 pound lift)
- Replaceable Bolt-on Steel Fenders
- Powder Coat Paint Process including: Frame, Channel, Actuator & Fenders
- D.O.T. Approved Tail Lamps, Stop Lamps, Turn Signal Lamps, Side Marker Lamps
- Weatherproof Trailer Light Wiring Harness



TRLR75XF

MQ POWER Tandem Axle Trailer

OPTIONAL TRAILER EQUIPMENT

- Bolt-on Electric Brake Coupler Plate with Electric-actuated Drum brakes (all axles)
- Electric Breakaway Safety Device (electric-actuated brakes)
- Adjustable 2-inch Ball Coupler
- Adjustable 2 5/16-inch Ball Coupler
- Adjustable 3-inch Pintle-eye Coupler
- Rear Stabilizer Stands or Swivel Jacks
- Side-Mounted Utility Storage Box
- Anti-Theft Wheel Lock
- Spare Tire with Locking Mount

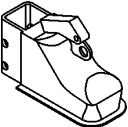
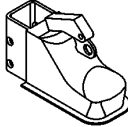
Coupler Options	
3" Pintle Eye 20,000 lbs. #EE36264	
2" Ball Coupler 10,000 lbs. #EE43254	
2-5/16" Ball Coupler 14,000 lbs. #EE43253	

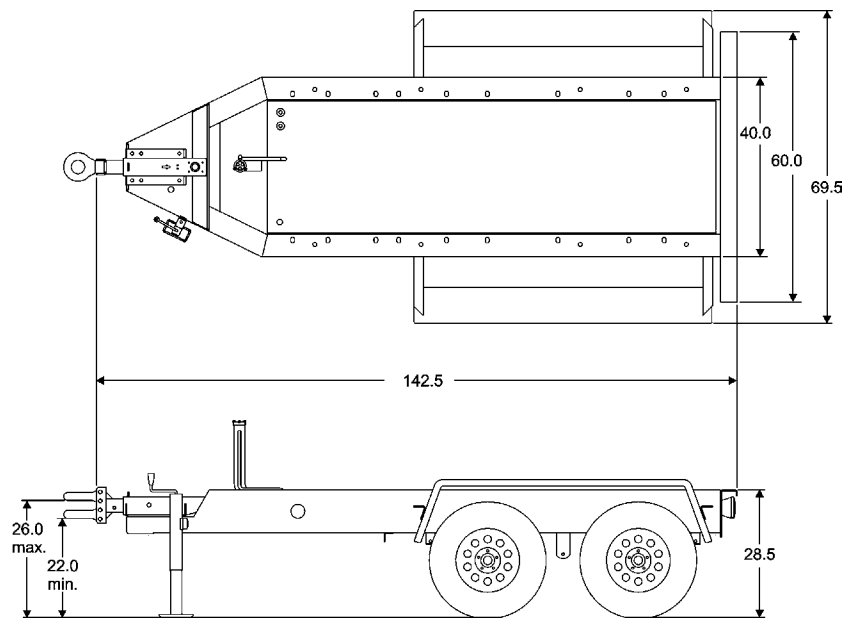

Trailer Weight	
Without fuel	With fuel
876 lbs. (397 kg)	1,586 lbs. (719 kg)

Your Multiquip dealer is:

