

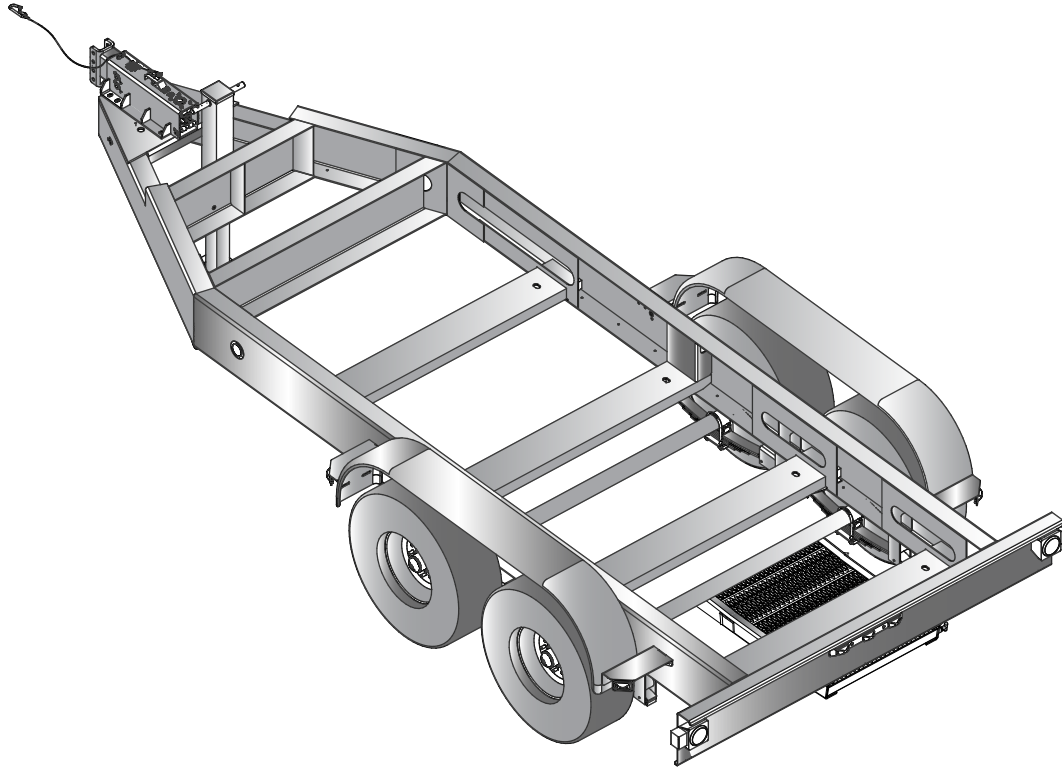

TRLRSG1600XF

MQ POWER Tandem Axle Trailer



TRLRSG1600XF Technical Data	
Gross Vehicle Weight Rating (GVWR) — 10,000 lbs. (4,536 kg)	Tire Size — ST235/80R116 LR-E
Gross Axle Weight Rating (GAWR) — 6,000 lbs (2,722 kg)	Wheel Bolt Pattern — 8 Lug on 6.5 in
Actuator Rating — 20,000 (9.072 kg)	Tire Load Rating — 3,520 lbs /1,596 kg (ea.)
Coupler Rating — See coupler options on back page.	Dimensions (LxWxH) — See back page

STANDARD TRAILER EQUIPMENT

- Fits MQ Power Generator Models SG1400C4F, SG1400C4FP, SG1600C4F and SG1600C4FP
- Straight Tandem-axle Design with Leaf Spring Suspension
- Heavy-Duty Welded Steel Frame Construction
- Formed Channel for Generator Mounting and Support
- Replaceable, Bolt-on Hydraulic Brake Actuator
- 4-hole Channel Allows 3-position, Adjustable Coupler Height; 4-inches O/A
- Heavy-duty, Tongue Mounted, Drop-leg Jack (rated 10,000 lbs/4,536 kg lift)
- Replaceable, Bolt-on Steel Fenders and Brackets
- Gloss Black Powder-Coated Frame, Channel, Actuator and Fenders
- D.O.T. Approved Tail Lamps, Stop Lamps, Turn Signal Lamps, Side Marker Lamps
- Weatherproof, Rubber Armored, 3-piece Trailer Light Wiring Harness
- Surge Hydraulic-actuated Drum Brakes (all axles)
- Hydraulic Uni-servo Drum Brakes — 12-inch Cluster
- D.O.T. Steel Brake Lines, Brass Tees and Rubber Hydraulic Brake Hoses



TRLRSG1600XF

MQ POWER Tandem Axle Trailer

OPTIONAL TRAILER EQUIPMENT

- Bolt-on Electric Brake Coupler Plate with Electric-actuated Drum Brakes (all axles — self-adjusting brake actuators)
- Electric Breakaway Safety Device (Electric-actuated Brakes)
- Spare Tire with Locking Mount
- Anti-Theft Wheel Lock

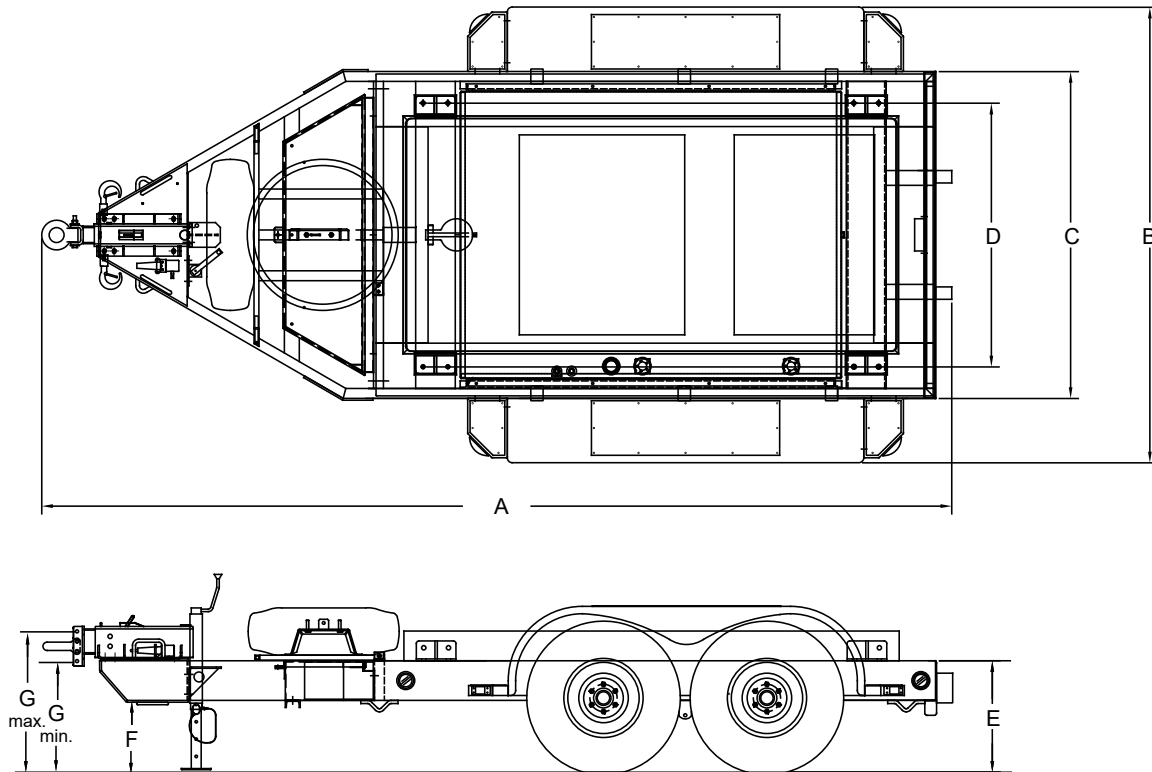

Trailer Dimensions							
A	B	C	D	E	F	G	
						Min	Max
183.75 in (4667.25 mm)	92 in (2336.8 mm)	66 in (1676.4 mm)	53.25 in (1352.55 mm)	22.5 in (571.5 mm)	14.12 in (358.65 mm)	28.44 in (722.38 mm)	22.44 in (569.98mm)

Trailer Weight
2,720 lbs. (12338 kg)*

* Weight is approximate

