



Trowel Arm Adjustment

Instructions

The following instructions are intended to assist the user with the adjustment of trowel arms on an MQ Whiteman power trowel. For information on operation, parts, safety or maintenance, refer to your trowel manual. If you do not have a manual for your trowel, contact MultiQuip at (800) 421-1244 for a replacement.

REQUIRED TOOLS

- Calipers
- 1/4" Allen wrench
- Adjustment Fixture P/N 1817 - for 1" arms **OR**
- Adjustment Fixture P/N 9177 - for 1 1/4" arms

WORK SAFELY!

Only a **qualified service technician** with proper training should perform this adjustment. Follow all shop safety rules when performing this procedure.

TROWEL ARM ADJUSTMENT

Shown in Figure 1 is the adjustment fixture. As each trowel arm is locked into the adjustment fixture, the trowel arm adjustment bolt is adjusted to where it contacts a stop on the adjustment fixture. This will consistently adjust all of the trowel arms, keeping the finisher as flat and evenly pitched as possible.

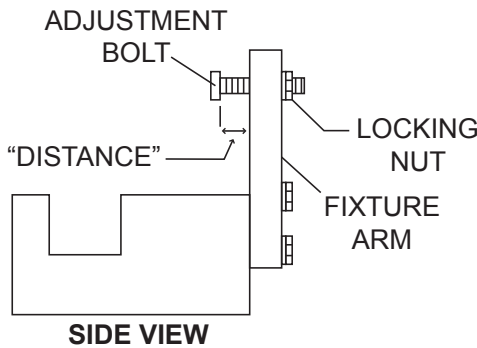

Figure 1. Adjustment Fixture

1. Make sure you have the correct adjustment fixture (see Required Tools) for your trowel arm.
2. Ensure the adjustment fixture arm is in the proper position (up or down) for your trowel arm rotation. Refer to Figure 2 and the Notice below for a guide.

NOTICE

Trowel arms with **CLOCKWISE** blade rotation use the adjustment fixture arm in the **UP** position (Figure 2A). Trowel arms with **COUNTERCLOCKWISE** blade rotation use the adjustment fixture arm in the **DOWN** position (Figure 2B).

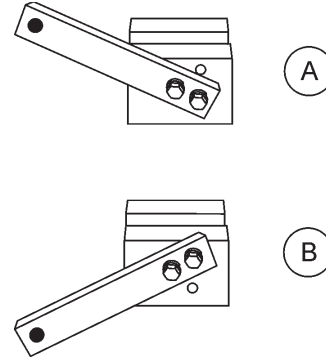

Figure 2. Adjustment Fixture Arm Position

3. Loosen the locking nut on the adjustment fixture arm (Figure 1).
4. Using calipers, adjust the fixture adjustment bolt to the distance (Figure 1) for your particular trowel as specified in Table 1.

Table 1. Fixture Adjustment Bolt Distance

Trowel Series		Fixture Adjustment Bolt Distance
B BA Epoxy HPHA HPLA M	J JA JWN J3036H55 STOW- SCT36/46	0.25 in. (6.33 mm)
BTO JTN JTO	HDA LD6	0.188 in. (4.77 mm)
HHN HHX HTN	HTO HTX44-TURBO	0.21 in. (5.33 mm)
HTX6H HTXD6I HTXG6DF	STX6H STXD6I STXDF	0.15 in. (3.81 mm)

5. Unscrew the locking bolts on the adjustment fixture and place the trowel arm into the fixture channel as shown in Figure 3. A thin shim may be required to cover the blade holes on the trowel arm. Make sure to align the trowel arm adjustment bolt with the fixture adjustment bolt.

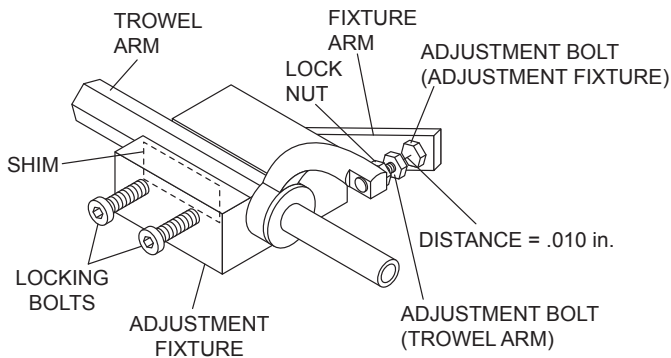

Figure 3. Trowel Arm Adjustment

6. Use an Allen wrench to tighten the locking bolts to secure the trowel arm in place.
7. Loosen the lock nut on the trowel arm. Turn the trowel arm adjusting bolt until it barely touches the fixture adjusting bolt (.010 inch distance).
8. Once the correct adjustment is made, tighten the lock nut on the trowel arm to lock it in place.
9. Loosen the locking bolts on the adjustment fixture and remove the trowel arm.
10. Repeat steps 5–9 for the remaining trowel arms.

HERE'S HOW TO GET HELP

**PLEASE HAVE THE MODEL AND SERIAL
NUMBER ON-HAND WHEN CALLING**

UNITED STATES

Multiquip Inc.

(310) 537- 3700
6141 Katella Avenue Suite 200
Cypress, CA 90630
E-MAIL: mq@multiquip.com
WEBSITE: www.multiquip.com

CANADA

Multiquip

(450) 625-2244
4110 Industriel Boul.
Laval, Quebec, Canada H7L 6V3
E-MAIL: infocanada@multiquip.com

UNITED KINGDOM

Multiquip (UK) Limited Head Office

0161 339 2223
Unit 2, Northpoint Industrial Estate,
Globe Lane,
Dukinfield, Cheshire SK16 4UJ
E-MAIL: sales@multiquip.co.uk

© COPYRIGHT 2020, MULTIQUIP INC.

Multiquip Inc and the MQ logo are registered trademarks of Multiquip Inc. and may not be used, reproduced, or altered without written permission. All other trademarks are the property of their respective owners and used with permission.

The information and specifications included in this publication were in effect at the time of approval for printing. Illustrations, descriptions, references and technical data contained in this document are for guidance only and may not be considered as binding. Multiquip Inc. reserves the right to discontinue or change specifications, design or the information published in this publication at any time without notice and without incurring any obligations.

