

DUMP CYLINDER CHARGE PUMP PSI TEST

The following instructions are intended to test and inspect charge pump pressure. Charge pump provides hydraulic oil to the dump cylinder in order to operate the tub. The charge pump pressure is checked at the dump cylinder.

IMPORTANT: Prior to testing the hydraulic system, ensure the engine is running at proper speed and at operating temperature. • *Engine Maximum Speed Specification* • **3600 RPM** •

BUGGY HYDRAULIC SPECIFICATIONS

Charge Pump • Minimum – 1000 PSI ± 50 PSI



WARNING: The following should only be done by qualified experienced service technicians. For your safety and the safety of others carefully read, understand and observe all instructions.

DIRECTIONAL CONTROL DUMP VALVE / CYLINDER LOCATION

The valve is mounted on the chassis and is located behind the left panel. To access the valve you will need to remove the access door.

- Position buggy on a flat surface, apply parking brake, start engine.
- Fully extend the dump cylinder into full up position.
- Apply safety rod to block tub in the upright position and shut engine off.
- Open access door.

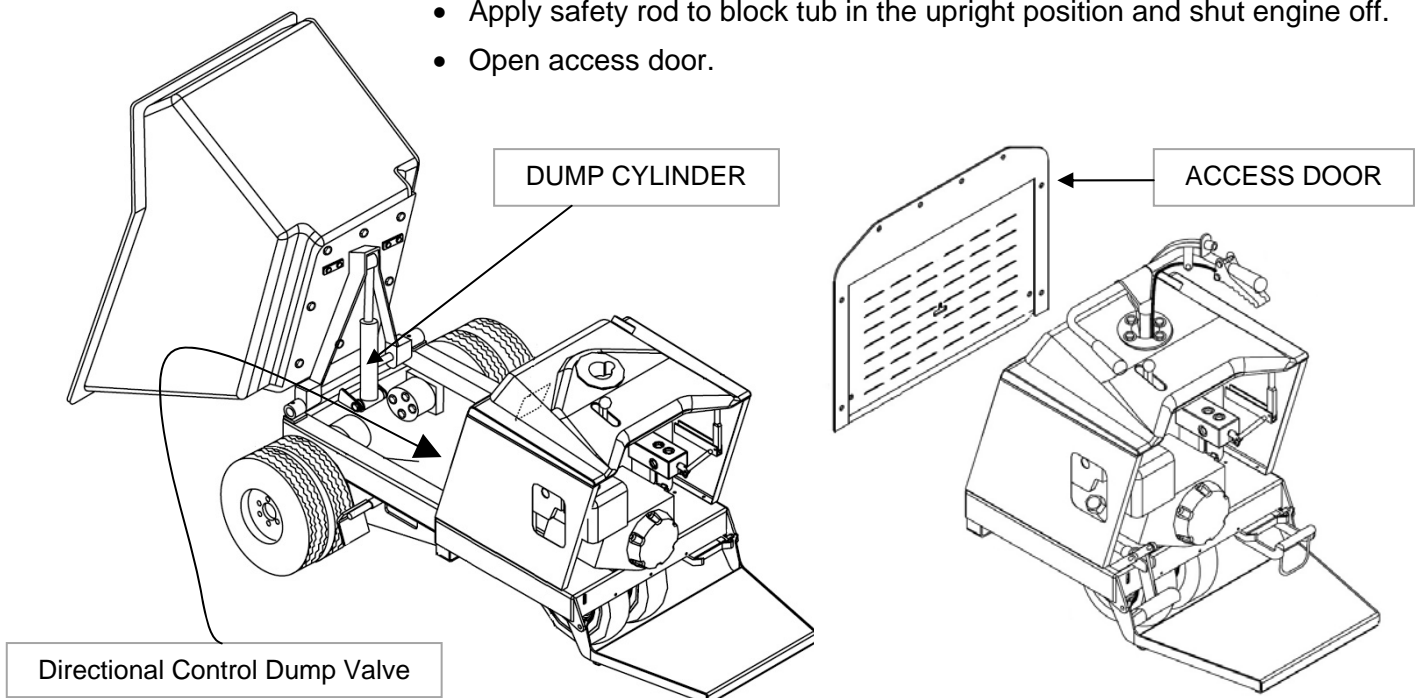

Continued on next page

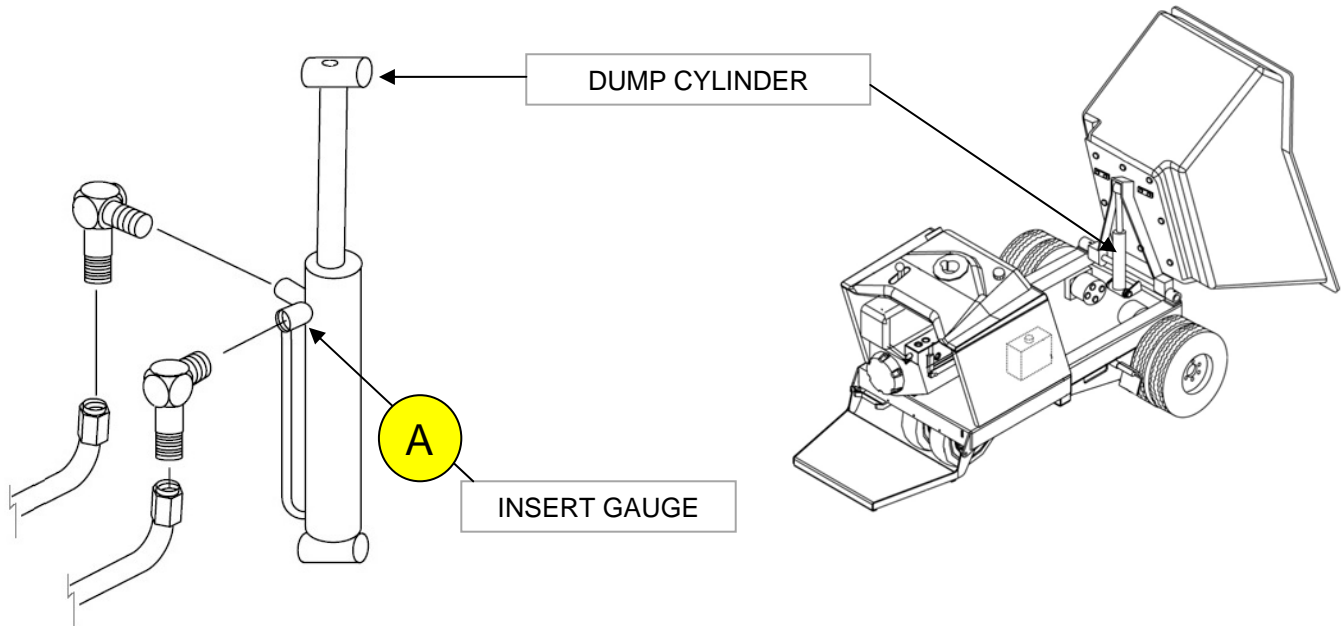

In order to check the valve pressure you will need to:

- Disconnect hydraulic hose from dump cylinder and remove fitting from port "A"
- Install a pressure gauge in Port "A".
- Pressure gauge used should be capable of reading a minimum of 3000 PSI

NOTE: when installing pressure gauge use correct size adaptors/reducers.



Continued on next page



The following should be done with extreme caution as high pressure hydraulic oil can spray during this test.



REMINDER: Ensure the engine is running at proper speed and at operating temperature.

• *Engine Maximum Speed Specification* • **3600 RPM** •

- Start the engine, Inspect and correct any oil leaks that may be present at test area before testing.
- Run engine at full speed for about 10 + minutes to bring hydraulic oil to operating temperature 100° F.
- Push the dump control lever to dump position for about 1–2 seconds to register the maximum PSI reading on the gauge. Maximum pressure should be set to 1000 PSI ± 50 PSI

ADJUSTMENT PROCEDURE

Remove hex cap covering the pressure relief valve on the directional control dump valve. With relief valve hex cap removed, a flat head screwdriver can be used to adjust the relief pressure. Turn the relief adjustment screw clockwise to increase pressure, counterclockwise to decrease pressure.



