



This bulletin is provided for technical reference and service related updates. If you have any questions, comments or do not wish to receive these e-mails, please reply to this e-mail or call the Service Technical Support Group 800 478-1244.

MAIN PUMP PSI TEST

The following instructions are intended to test and inspect the main pump pressure. The main pump pressure is checked at the directional control valve.

IMPORTANT: Prior to testing any of the hydraulic system, ensure the engine is running at proper speed. During test engine should be running at full speed. • *Engine Maximum Speed Specification* • **3600 RPM** •

HYDRAULIC SPECIFICATIONS
Main Pump • Minimum – 2,250 PSI



The following should be done with extreme caution as high pressure hydraulic oil can spray during this test.



TRAVEL DIRECTIONAL CONTROL VALVE LOCATION

The valve is mounted on the chassis and is located next to the engine.

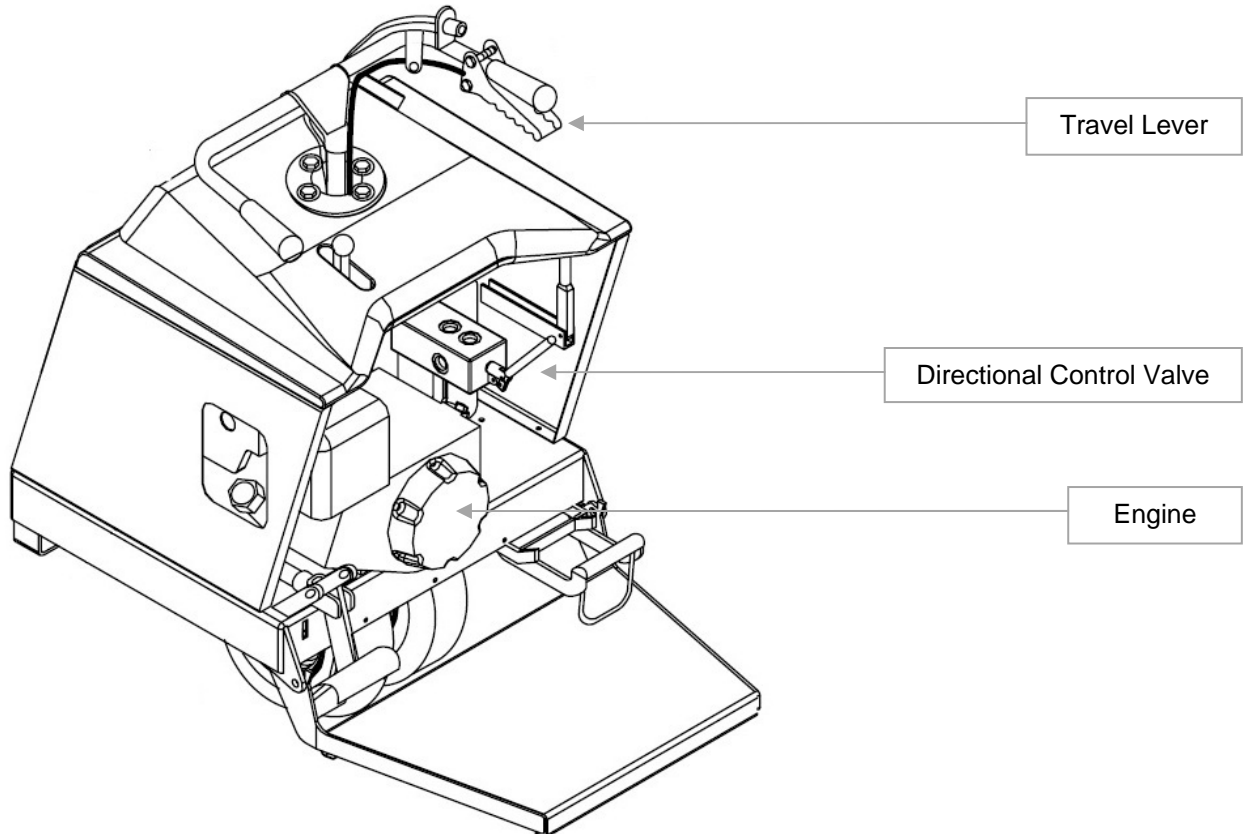

Continued on next page

IMPORTANT: Prior to testing any of the hydraulic system, ensure the engine is running at proper speed. During test engine should be running at full speed. • *Engine Maximum Speed Specification* • **3600 RPM** •

- Ensure machine is warmed up to proper operating temperature (approximate 100° Fahrenheit)
- Position buggy on a flat surface, apply parking brake and turn engine OFF.
- On the directional control valve PORT "A", disconnect and plug hydraulic hose.
- Remove 90° elbow and install 5000 PSI pressure gauge into PORT "A".
- Start engine, inspect and correct any oil leaks that may be present.
- Place the directional control valve in the reverse position.
- Squeeze the travel lever all the way for about 2-3 seconds to register a pressure reading on the gauge.



Hydraulic Hose

Hydraulic Specification - Main Pump Minimum = 2,250 PSI

- If the PSI is not to specification, inspect the directional control valve and all other possible components. The Main Pump is factory set and cannot be adjusted.
- Refer to Technical Information document "Directional Control Valve

