

## IMPORTANT SAFETY RECALL 20V-021

Date: 01/24/20  
To: WT5C/WT5CSG Water Trailer Owners  
From: Multiquip Product Department  
Subject: Safety Chains — **INSPECTION REQUIRED**

---



Dear Multiquip Customer,

This notice is sent to you in accordance with the requirements of the National Traffic and Motor Vehicle Safety Act. Multiquip has decided that a defect which relates to motor vehicle safety exists in certain model year 2019 WT5C trailers. The trailer safety chains may be too short to properly connect to a tow vehicle.

Our records indicate that your company purchased one or more WT5C or WT5CSG Water Trailers. We are asking owners of these trailers to immediately inspect the connection points of the trailer's safety chains. A limited number of Water Trailers were shipped with mounting points that result in safety chain length that is inadequate for and may interfere with proper tow operation. Continued use of affected trailers without the inspection and, if applicable, corrective action could result in damage to the water trailer and/or tow vehicle. **Failure to properly connect safety chains may result in death or serious injury if the trailer uncouples from the tow vehicle during operation.**

**The safety chains will be relocated free of charge.**

---

The accompanying Service Bulletin details the inspection procedure and corrective actions, if required. No action is needed if the trailer safety chains are connected to the V-rings as shown in the Service Bulletin.

**WARNING: Failure to perform this corrective action on affected trailers may result in inadequate safety chain performance and damage to the trailer and/or tow vehicle. Failure to properly connect safety chains may result in death or serious injury if the trailer uncouples from the tow vehicle during operation.**

If you no longer own this trailer, please contact Multiquip to provide the new owner information. Multiquip will then contact the new owner.

Your prompt attention to this matter is appreciated. If you have questions, please contact the Multiquip Technical Support Department at 800-478-1244 or [techsupport@multiquip.com](mailto:techsupport@multiquip.com).

### PARTS ORDERING INFORMATION

**You must place a parts order with the Multiquip Parts Department to ensure proper shipment.**

- Upon placement of the order, the parts needed will be shipped to you.
- Use Multiquip's SmartEquip™ Online Parts Order System for faster service.

### WARRANTY INFORMATION

**Campaign:** Reference No. WT20191031

File your claim online via E-Warranty at <http://service.multiquip.com/warranty-support.html> or contact our warranty department for assistance at 800-421-1244.

**Labor Allowance:** 0.25 hour total flat rate for relocation of safety chains.

If after having attempted to take advantage of this recall you believe you have not been able to have your trailer remedied without charge and within a reasonable amount of time, you may submit a complaint to the Administrator, National Highway Traffic Safety Administration, 1200 New Jersey Ave., S.E., Washington, D.C. 20590 or call the toll-free vehicle safety hotline at 1-888-327-4236 (TTY: 1-800-424-9153); or go to <http://www.safercar.gov>.



# Service Bulletin

## WT5C/WT5CSG Safety Chains Inspection

<b>Product Group:</b> Water Trailers	<b>Date Issued:</b> 01/24/20	<b>Expiration Date:</b> N/A	<b>Bulletin No.</b> WT20191031
---	---------------------------------	--------------------------------	-----------------------------------

### Models/Serial Numbers Affected:

WT5C	54401 - 54404, 54419 - 54436, 54444 - 54448, 54452 - 54454, 54526 - 54542, 54553 - 5559, 54582 - 54587, 54717 - 54723, L027063 - L027067, L027114 - L027133, L027188 - L027207
WT5CSG	54282 - 54288

### Details

#### Problem:

A limited number of WT5C and WT5CSG Water Trailers have safety chain mounting points that result in safety chain length that is inadequate for and may interfere with proper tow operation. Continued use of these affected trailers could result in damage to the water trailer and/or tow vehicle.

**WARNING: Failure to perform this corrective action on affected trailers may result in inadequate safety chain performance and damage to the trailer and/or tow vehicle. Failure to properly connect safety chains may result in death or serious injury if the trailer uncouples from the tow vehicle during operation.**

#### Solution:

If you have a WT5C or WT5CSG trailer with the safety chains mounted to the trailer frame with a clamp plate as shown below, corrective action requires installing new hardware and relocating the chains to the V-rings as detailed below. No change is required if the chains are properly connected to the V-rings. **Only water trailers within the stated serial number ranges require inspection. The serial number of the water trailer is stamped into the top of the A-frame at the junction of the tongue and/or the last 5 digits of the VIN tag.**

### Parts Information

#### IMPORTANT!

Use only original Multiquip chains and hardware!

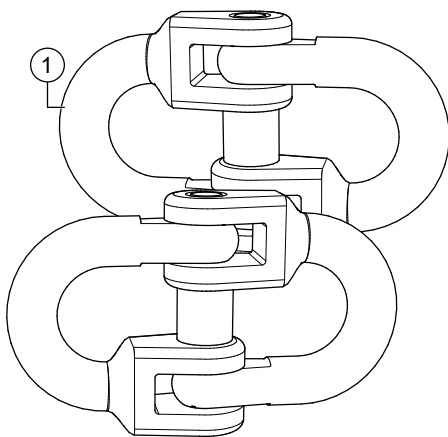

Figure 1. Hammerlok Link Coupler (Assembled)

Table 1. Hammerlok Link Coupler

Item No.	Part No.	Description	Qty.	Remarks
1	EE44113	Link, Hammerlok Coupling (Painted)	2	Includes items 2-5
2		Hammerlok Link #1	2	
3		Hammerlok Link #2	2	
4		Load Pin	2	
5		Load Pin Tube	2	

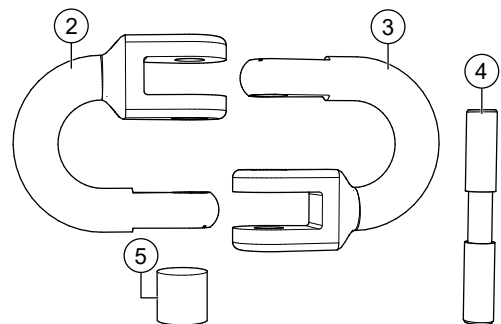

Figure 2. Hammerlok Link Coupler (Parts)

## WORK SAFELY!

***Only a qualified service technician should perform this procedure.*** Follow all shop safety rules when performing this procedure.

## SAFETY CHAIN INSPECTION

Locate the safety chains on your water trailer.

If the safety chains are attached to the welded V-rings (Figure 3A) located on the trailer tongue, the chains **DO NOT** need to be moved. Please disregard this notice.

If the safety chains are attached to the A-frame via a clamp plate as shown in Figure 3B, proceed as follows to reconnect the chains to the welded V-rings (Figure 3A) located on the trailer tongue.

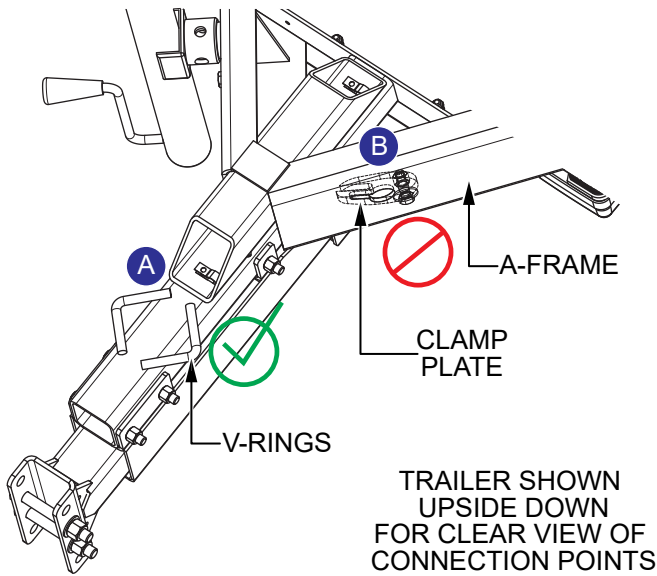

**Figure 3. Location of Safety Chains**

## PREPARATION

1. Make sure the water trailer is not in operation.
2. Place the water trailer on secure, level ground with chock blocks underneath each wheel to prevent it from rolling.

## TOOLS

- 3/4" wrench or socket
- Hammer or mallet

## SAFETY CHAIN RELOCATION

1. Remove and discard the bolts, nuts and washers (Figure 4) securing the clamp plates to the A-frame.

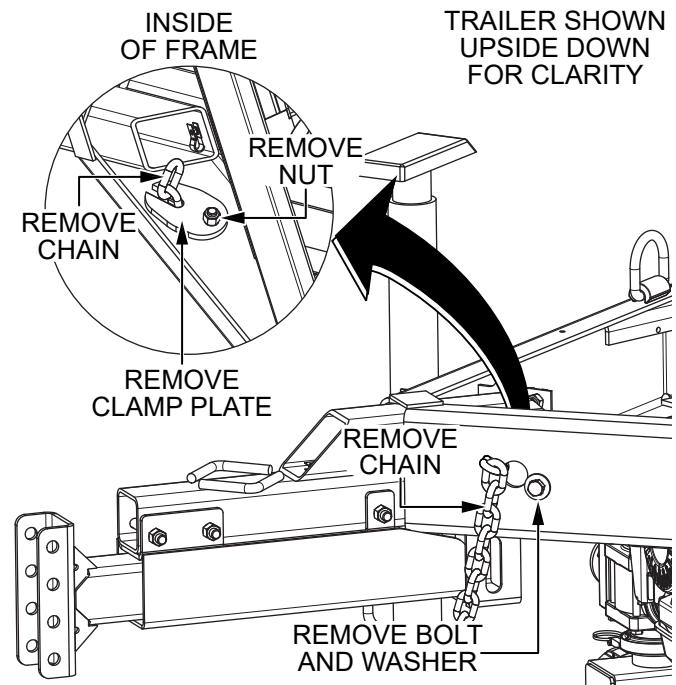
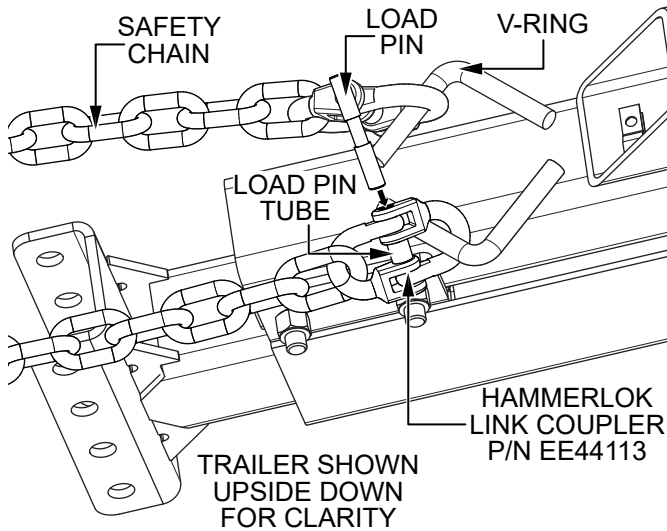

**Figure 4. Remove and Discard Clamp Plates and Hardware**

2. Remove the safety chains from the clamp plates (Figure 4) and discard the clamp plates.

3. Connect the safety chains to the welded V-rings using the Hammerlok link couplers (P/N EE44113) as shown in Figure 5.

Loop one half of the Hammerlok link onto the V-ring, then loop the other half onto the end of the safety chain. Connect these two link sections together by driving the load pin through the link sections and the load pin tube.



**Figure 5. Reconnect Safety Chains**

## **HERE'S HOW TO GET HELP**

PLEASE HAVE THE MODEL AND SERIAL  
NUMBER ON-HAND WHEN CALLING

### **UNITED STATES**

#### ***Multiquip Inc.***

(310) 537- 3700  
6141 Katella Avenue Suite 200  
Cypress, CA 90630  
E-MAIL: [mq@multiquip.com](mailto:mq@multiquip.com)  
WEBSITE: [www.multiquip.com](http://www.multiquip.com)

### **CANADA**

#### ***Multiquip***

(450) 625-2244  
4110 Industriel Boul.  
Laval, Quebec, Canada H7L 6V3  
E-MAIL: [infocanada@multiquip.com](mailto:infocanada@multiquip.com)

### **UNITED KINGDOM**

#### ***Multiquip (UK) Limited Head Office***

0161 339 2223  
Unit 2, Northpoint Industrial Estate,  
Globe Lane,  
Dukinfield, Cheshire SK16 4UJ  
E-MAIL: [sales@multiquip.co.uk](mailto:sales@multiquip.co.uk)

© COPYRIGHT 2020, MULTIQUEIP INC.

Multiquip Inc and the MQ logo are registered trademarks of Multiquip Inc. and may not be used, reproduced, or altered without written permission. All other trademarks are the property of their respective owners and used with permission.

The information and specifications included in this publication were in effect at the time of approval for printing. Illustrations, descriptions, references and technical data contained in this document are for guidance only and may not be considered as binding. Multiquip Inc. reserves the right to discontinue or change specifications, design or the information published in this publication at any time without notice and without incurring any obligations.