

# WTB-16

COMBINATION SWITCH CONTINUITY		IG	GND	BAT	LO	ST
OFF						
ON	○	○				
ST	○		○	○	○	○

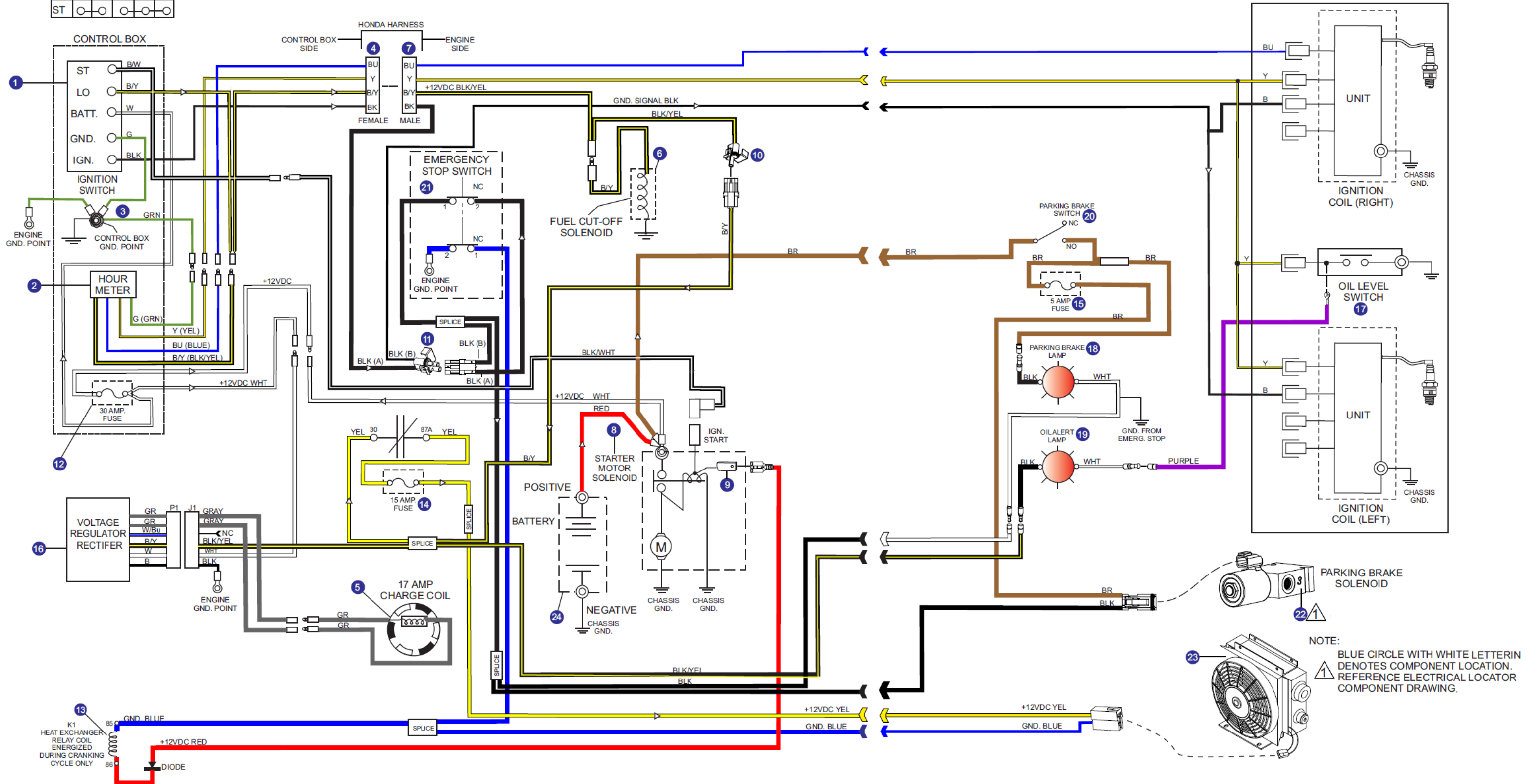

NOTE:  
 BLUE CIRCLE WITH WHITE LETTERING  
 DENOTES COMPONENT LOCATION.  
 REFERENCE ELECTRICAL LOCATOR  
 COMPONENT DRAWING.