



Walk-Behind Trowels

HD Block Installation

The following instructions are intended to assist the user in the installation of the HD Block to the handle of your Multiquip walk-behind trowels. It is not intended to take the place of the Operation and Parts Manual shipped with the trowel. Refer to the Operation and Parts Manual for SAFETY, OPERATION, and MAINTENANCE Information. If you did not receive a manual with your trowel, contact Multiquip at (800) 421-1244 for a replacement.

REQUIRED TOOLS

- Socket set
- Wrench
- Needle-nose Pliers

PARTS

Verify that all parts are accounted for. See Figure 1 and Table 1.

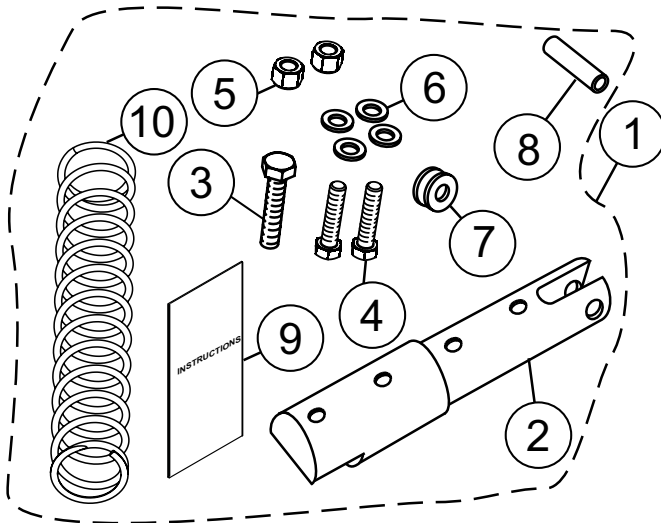

Figure 1. HD Block Installation Kit

Table 1. HD Block Parts

Item No.	Part No.	Description	Qty.	Remarks
1	22226	HD Block Installation Kit	1	Includes items 2-9
2	20460	Block Support	1	
3	20473	Screw Hex Head 3/8-16 x 3"	1	
4	1121	Screw Hex Head 3/8-16 x 2-3/4"	3	
5	10133	3/8-16 Nyloc Nut	4	
6	10136	Flat Washer SAE 3/8	8	
7	1118	Pulley Assy, Pitch Cable	1	
8	20279	Pin, Support Block 3/8 x 1.59	1	
9	22227	HD Block Installation Instructions	1	
10	21746	Spring, 0.42 OD x 2.5L Primary Throttle Return	1	

WORK SAFELY!

Only a **qualified service technician** with proper training should perform this installation. Follow all shop safety rules when performing this installation.

PROCEDURE

1. Clamp or steady handle tube in vise with access holes facing up.
2. Install pulley and pin on the HD block as shown in Figure 2.

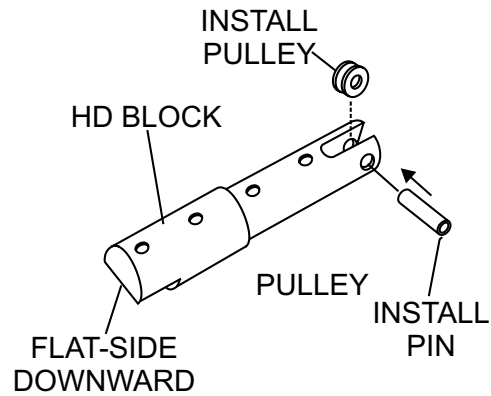

Figure 2. Pulley Installation

3. Remove the two brass nuts from the end of the cable. See Figure 3.

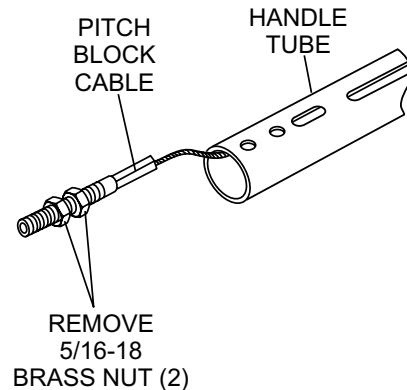

Figure 3. Removing Brass Nuts

- With pitch block cable pulled through handle tube, thread cable around pulley as shown in Figure 4. The HD block should be positioned with the flat side downward. Keep the pulley from coming loose by holding pin in place with your thumb.

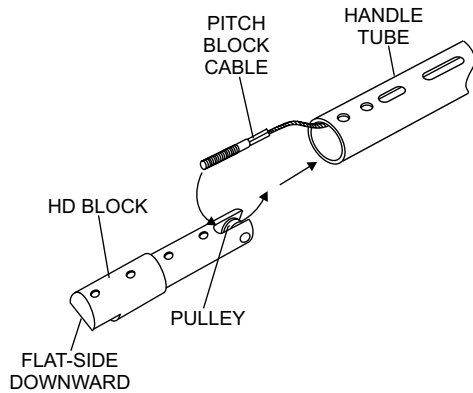

Figure 4. Threading Cable Through Pulley

- Pull cable end and loop back toward handle and insert back into handle tube as shown in Figure 4.
- Pull cable end up and out of first elongated slot in the handle using needle-nose pliers. See Figure 5

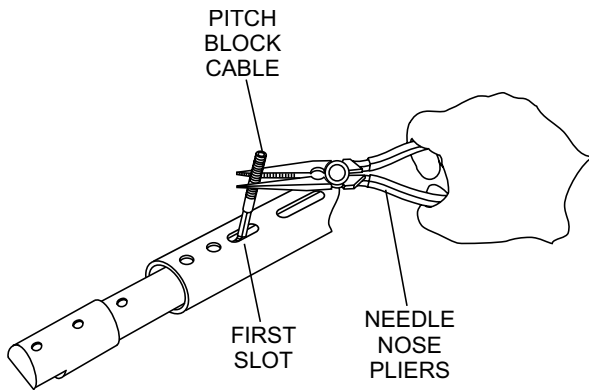

Figure 5. Pulling Out Cable End

- Rotate block so flat side is now upwards. Align mounting holes as shown in Figure 6.

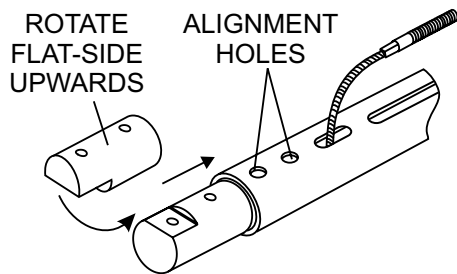

Figure 6. Mounting Holes Alignment

- Install Hex Head Screw (3/8-16 x 3") until snug as shown in Figure 7.

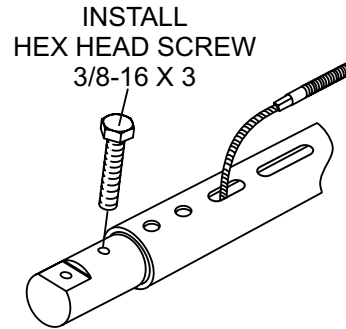

Figure 7. Hex Head Screw Installation

- Install Hex Head Screws (3/8-16 x 2 3/4") from bottom. Secure with flat washers and 3/8" locking nuts until snug as shown in Figure 8.

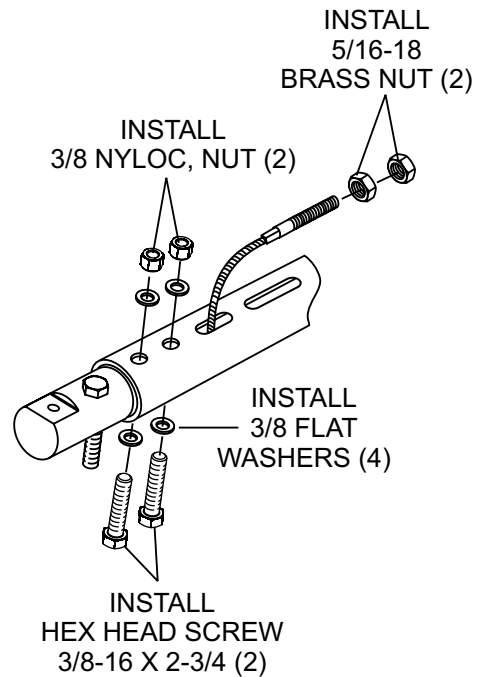

Figure 8. Securing the HD Block

- Install brass nuts back onto the end of the cable. See Figure 8.

THROTTLE CABLE INSTALLATION

Refer to Figure 9 for the location of components.

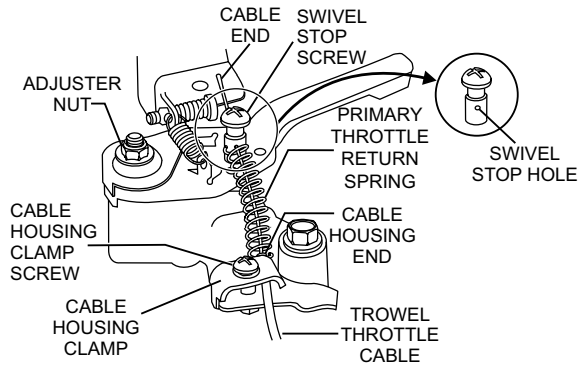

Figure 9. Throttle Cable Installation

1. Uncoil the throttle cable and housing.
2. Check that the throttle cable is fed through the tube on the underside of the handle and secured to the upper handle and main tube with the zip ties.
3. Place the throttle in the idle position.
4. Back off both the cable housing clamp screw and the swivel stop screw.
5. Place the primary throttle return spring (P/N 21746) between the cable housing clamp and the swivel stop screw.
6. Feed the cable assembly through the cable housing clamp, primary throttle return spring, and swivel stop hole, until the cable housing extends under the housing clamp to its far edge.
7. Ensure that the cable housing is seated in the throttle cable receiver. Tighten the cable housing clamp screw.
8. Pull cable end with pliers to remove slack.
9. Tighten swivel stop screw to clamp cable.
10. Adjust cable tension by loosening the lock nut on the throttle cable receiver (see Figure 10), loosening or tightening the adjusting nut below it, then retightening the lock nut.

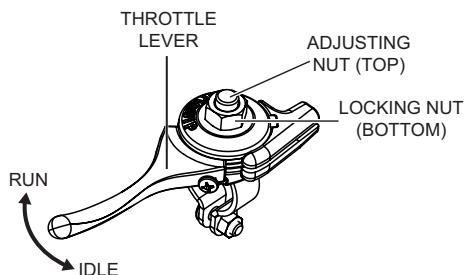

Figure 10. Adjusting Cable Tension

NOTICE

If the throttle lever does not return to the "neutral" position with throttle backed off, loosen adjusting nut 1/2 turn at a time, tighten and recheck. Readjust throttle tension as necessary.

Centrifugal Stop Switch Connection

NOTICE

Safety stop switches are equipped with 2 wires. Connect bottom **BLACK/RED** wire (Figure 11) directly to engine ground.

1. Connect the black tail wire from the engine to the **top black** safety stop wire from the centrifugal stop switch as shown in Figure 11.

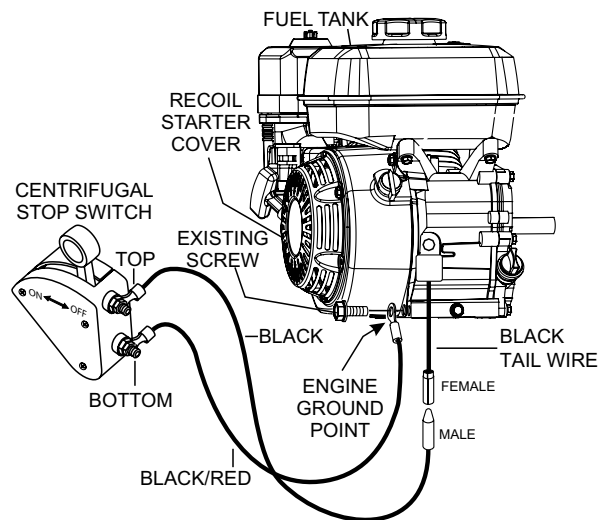

Figure 11. Safety Stop Switch Connections

2. Using a 10MM socket, remove the existing bottom mounting screw on the recoil starter cover (Figure 11) and connect the **bottom black/red** wire from the centrifugal stop switch to this engine ground point.
3. Reinstall mounting screw and tighten securely.
4. Check that the wires are secured to the main tube with zip ties.



Walk-Behind Trowels

HD Block Installation

HERE'S HOW TO GET HELP

PLEASE HAVE THE MODEL AND SERIAL
NUMBER ON-HAND WHEN CALLING

UNITED STATES

Multiquip Corporate Office

18910 Wilmington Ave. Tel. (800) 421-1244
Carson, CA 90746 Fax (310) 537-3927
Contact: mq@multiquip.com

Service Department

800-421-1244 Fax: 310-537-4259
310-537-3700

Technical Assistance

800-478-1244 Fax: 310-943-2238

MQ Parts Department

800-427-1244 Fax: 800-672-7877
310-537-3700 Fax: 310-637-3284

Warranty Department

800-421-1244 Fax: 310-943-2249
310-537-3700

CANADA

Multiquip

4110 Industriel Boul. Tel: (450) 625-2244
Laval, Quebec, Canada H7L 6V3 Tel: (877) 963-4411
Contact: infocanda@multiquip.com Fax: (450) 625-8664

UNITED KINGDOM

Multiquip (UK) Limited Head Office

Unit 2, Northpoint Industrial Estate, Tel: 0161 339 2223
Globe Lane, Fax: 0161 339 3226
Dukinfield, Cheshire SK16 4UJ
Contact: sales@multiquip.co.uk

© COPYRIGHT 2016, MULTIQUIP INC.

Multiquip Inc and the MQ logo are registered trademarks of Multiquip Inc. and may not be used, reproduced, or altered without written permission. All other trademarks are the property of their respective owners and used with permission.

The information and specifications included in this publication were in effect at the time of approval for printing. Illustrations, descriptions, references and technical data contained in this document are for guidance only and may not be considered as binding. Multiquip Inc. reserves the right to discontinue or change specifications, design or the information published in this publication at any time without notice and without incurring any obligations.

Your Local Dealer is:

